

JVC®

SERVICE MANUAL

CD/DVD LIBRARY

MC-8100LU

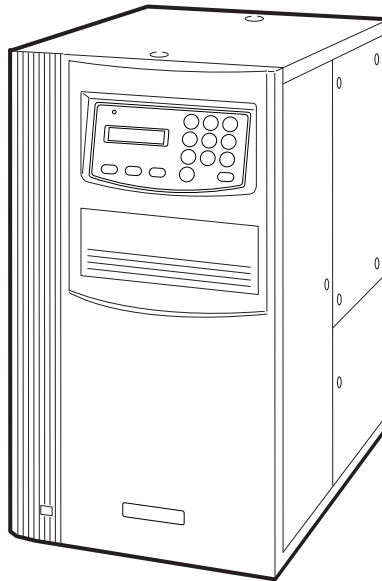

SPECIFICATIONS

Number of stored discs : 100	Applicable options	Availabel drives	Compatible discs
Number of magazines : 2	Drives	: DVD-RAM drive	
Operating environment : Temperature : 5 °C to 35 °C (41 °F to 95 °F)		DVD-RAM/R drive	Write/Read DVD-RAM (Ver. 2.1), DVD-R (for General), CD-R, CD-RW
(Note 1)			Read DVD-ROM, CD-ROM
Humidity : 10 % to 80 % (no condensation)			
Rated power voltage : AC120 V to 240 V			
Rated power frequency : 50 Hz / 60 Hz			
Rated current : 1.4 A to 0.8 A (max. value), 1.1 A to 0.6 A (4 Drives are loaded)			
Power Consumption : 105 W (Reference value, 4 DVD-RAM drives are loaded)			
Interface : 68-pin external SCSI connector			
Drive slots rack bays : 4			
Media size : 12 cm discs			
Note 1 : When using 4 of the MC-R434U units together, be sure that the room temperature is between 5 °C and 30 °C.	Carrier : Single-sided / Double-sided compatible disc carrier: MC-CF10U		
	Magazine : Magazine set: MC-M25U (B)		
	Weight : 42 kg (Excluding the discs and optional equipment)		

TABLE OF CONTENTS

Section	Title	Page	Section	Title	Page
Important Safety Precautions					
INSTRUCTIONS					
1.	CIRCUIT BOARD COMPATIBILITY	1-1	3.6	SCSI SCHEMATIC DIAGRAM	3-6
2.	PRODUCT SPECIFIC SERVICE ITEMS		3.7	SCSI CIRCUIT BOARD	3-7
2.1	REMOVAL OF MAJOR PARTS	2-1	3.8	CARRIER SCHEMATIC DIAGRAM	3-8
2.1.1	REPLACEMENT OF FUSES AND BATTERIES	2-1	3.9	CARRIER CIRCUIT BOARD	3-9
2.1.2	OPENING/CLOSING THE DOOR AND PANEL REMOVAL	2-2	3.10	MAIL SLOT SCHEMATIC DIAGRAM	3-10
2.1.3	REMOVING THE MAGAZINE	2-3	3.11	S. MOT SCHEMATIC DIAGRAM	3-10
2.1.4	REMOVING THE DRIVE	2-4	3.12	MAIL SLOT CIRCUIT BOARD	3-11
2.1.5	REMOVING THE SIDE STAY R	2-4	3.13	S. MOT CIRCUIT BOARD	3-11
2.1.6	REMOVING THE CARRIER MECHANISM	2-5	3.14	LVD SCHEMATIC DIAGRAM	3-12
2.1.7	REMOVING THE SIDE PANEL L	2-6	3.15	LVD CIRCUIT BOARD	3-13
2.1.8	REMOVING THE SIDE PANEL R	2-6	3.16	DISPLAY SCHEMATIC DIAGRAM	3-14
2.1.9	REMOVING THE REAR PANEL	2-6	3.17	DISPLAY CIRCUIT BOARD AND OTHER BOARD	3-15
2.1.10	REMOVING THE POWER SUPPLY UNIT	2-6	3.18	BLOCK DIAGRAMS OF IC S	3-16
2.1.11	REMOVING THE CHASSIS PCB	2-7			
2.1.12	REMOVING THE SCSI PCB	2-7	4.	EXPLODED VIEW AND PARTS LIST	
2.1.13	REMOVING THE MAIL SLOT	2-8	4.1	FINAL ASSEMBLY M1	4-1
2.1.14	REMOVING THE TOP PANEL	2-8	4.2	FINAL ASSEMBLY PARTS LIST M1	4-2
2.1.15	REMOVING THE U/D MOTOR	2-9	4.3	CARRIER MECHANISM ASSEMBLY M2	4-5
2.1.16	HOW TO OPERATE WITH THE DOOR OPEN (FOR SERVICING)	2-9	4.4	CARRIER MECHANISM ASSEMBLY PARTS LIST M2	4-6
2.2	SPECIAL OPERATION MODE	2-10	4.5	MAIL SLOT ASSEMBLY M3	4-7
2.2.1	RUNNING MODES	2-10	4.6	MAIL SLOT ASSEMBLY PARTS LIST M3	4-8
2.2.2	ACCESS COUNTER CLEARANCE	2-12	4.7	MAGAZINE ASSEMBLY M4	4-9
2.2.3	MANUAL OPERATION	2-12	4.8	MAGAZINE ASSEMBLY PARTS LIST M4	4-9
2.2.4	PACKING MODE	2-14	4.9	IL BRACKET ASSEMBLY M5	4-10
2.2.5	TRAY AUTO RETURN MODE	2-14	4.10	IL BRACKET ASSEMBLY PARTS LIST M5	4-10
2.2.6	MEMORY CLEAR MODE	2-14	4.11	U/D MECHANISM ASSEMBLY M6	4-11
2.2.7	DISC/TRAY CHECK MODE	2-15	4.12	U/D MECHANISM ASSEMBLY PARTS LIST M6	4-12
2.2.8	AUTO CHECK MODE	2-15	5.	ELECTRICAL PARTS LIST	
2.2.9	DRIVE DETECTION MODE	2-15	5.1	CHASSIS BOARD ASSEMBLY PARTS LIST 01	5-2
2.2.10	AUTO DISC/TRAY CHECK ON/OFF SETTING	2-16	5.2	CONNECTOR BOARD ASSEMBLY PARTS LIST 02	5-5
2.3	SELF-DIAGNOSTIC DISPLAY	2-16	5.3	RS232C BOARD ASSEMBLY PARTS LIST 03	5-5
2.3.1	DISPLAYING TROUBLE HISTORY	2-16	5.4	S.MOT BOARD ASSEMBLY PARTS LIST 04	5-5
2.3.2	DISPLAY WHEN TROUBLE OCCURS	2-17	5.5	SCSI BOARD ASSEMBLY PARTS LIST 05	5-6
2.3.3	ERASING THE TROUBLE HISTORY	2-18	5.6	DISPLAY BOARD ASSEMBLY PARTS LIST 06	5-7
2.3.4	ERROR CODE LIST	2-18	5.7	MAIL CN BOARD ASSEMBLY PARTS LIST 07	5-7
2.4	MAINTENANCE MODE	2-19	5.8	ROT SENSOR BOARD ASSEMBLY PARTS LIST 08	5-7
2.4.1	OUTLINE	2-19	5.9	MG SENSOR BOARD ASSEMBLY PARTS LIST 09	5-7
2.4.2	ELECTRICAL SPECIFICATIONS	2-19	5.10	CARRIER MEC BOARD ASSEMBLY PARTS LIST 10	5-8
2.4.3	MAINTENANCE TYPES AND CONDITIONS	2-19	5.11	R CATCH BOARD ASSEMBLY PARTS LIST 11	5-8
2.4.4	ACTIVATING THE MAINTENANCE MODE	2-19	5.12	L CATCH BOARD ASSEMBLY PARTS LIST 12	5-8
2.4.5	MAINTENANCE PROGRAM	2-19	5.13	LOADING BOARD ASSEMBLY PARTS LIST 13	5-9
2.5	MAINTENANCE AND PERIODICAL CHECK	2-20	5.14	TRAY LOCK BOARD ASSEMBLY PARTS LIST 14	5-9
2.6	COUNTERMEASURES AGAINST MECHANICAL TROUBLE (FOR MC-R400U)	2-21	5.15	LANE2 SEN BOARD ASSEMBLY PARTS LIST 15	5-9
2.7	COUNTERMEASURES AGAINST MECHANICAL TROUBLE (FOR MC-R200U)	2-22	5.16	L ADD SEN BOARD ASSEMBLY PARTS LIST 16	5-9
3.	DIAGRAMS AND CIRCUIT BOARDS		5.17	R ADD SEN BOARD ASSEMBLY PARTS LIST 17	5-9
3.1	CD/DVD LIBRARY BLOCK DIAGRAM	3-1	5.18	DISK SEN R BOARD ASSEMBLY PARTS LIST 18	5-9
3.2	CHASSIS BLOCK DIAGRAM	3-2	5.19	DISK SEN T BOARD ASSEMBLY PARTS LIST 19	5-10
3.3	OVERALL WIRING DIAGRAM	3-3	5.20	MAIL SLOT BOARD ASSEMBLY PARTS LIST 20	5-10
3.4	CHASSIS SCHEMATIC DIAGRAM	3-4	5.21	SENSOR BOARD ASSEMBLY PARTS LIST 21	5-10
3.5	CHASSIS CIRCUIT BOARD	3-5	5.22	POSI IN BOARD ASSEMBLY PARTS LIST 22	5-10
			5.23	LVD BOARD ASSEMBLY PARTS LIST 23	5-11
			6.	PACKING	
			6.1	PACKING ASSEMBLY M7	6-1
			6.1.2	PACKING ASSEMBLY PARTS LIST M7	6-1

Important Safety Precautions

Prior to shipment from the factory, JVC products are strictly inspected to conform with the recognized product safety and electrical codes of the countries in which they are to be sold. However, in order to maintain such compliance, it is equally important to implement the following precautions when a set is being serviced.

●Precautions during Servicing

1. Locations requiring special caution are denoted by labels and inscriptions on the cabinet, chassis and certain parts of the product. When performing service, be sure to read and comply with these and other cautionary notices appearing in the operation and service manuals.

2. Parts identified by the \triangle symbol and shaded (■) parts are critical for safety.
Replace only with specified part numbers.
Note: Parts in this category also include those specified to comply with X-ray emission standards for products using cathode ray tubes and those specified for compliance with various regulations regarding spurious radiation emission.

3. Fuse replacement caution notice.
Caution for continued protection against fire hazard.
Replace only with same type and rated fuse(s) as specified.

4. Use specified internal wiring. Note especially:
1) Wires covered with PVC tubing
2) Double insulated wires
3) High voltage leads

5. Use specified insulating materials for hazardous live parts.
Note especially:
1) Insulation Tape 3) Spacers 5) Barrier
2) PVC tubing 4) Insulation sheets for transistors

6. When replacing AC primary side components (transformers, power cords, noise blocking capacitors, etc.) wrap ends of wires securely about the terminals before soldering.

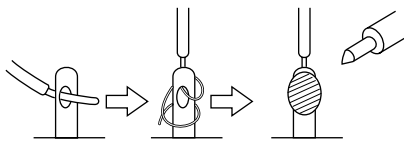

Fig.1

7. Observe that wires do not contact heat producing parts (heatsinks, oxide metal film resistors, fusible resistors, etc.)

8. Check that replaced wires do not contact sharp edged or pointed parts.

9. When a power cord has been replaced, check that 10-15 kg of force in any direction will not loosen it.

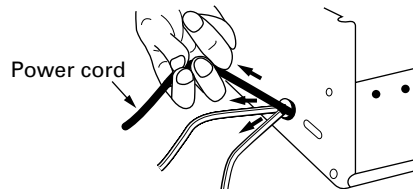

Fig.2

10. Also check areas surrounding repaired locations.

11. Products using cathode ray tubes (CRTs)
In regard to such products, the cathode ray tubes themselves, the high voltage circuits, and related circuits are specified for compliance with recognized codes pertaining to X-ray emission. Consequently, when servicing these products, replace the cathode ray tubes and other parts with only the specified parts. Under no circumstances attempt to modify these circuits. Unauthorized modification can increase the high voltage value and cause X-ray emission from the cathode ray tube.

12. Crimp type wire connector

In such cases as when replacing the power transformer in sets where the connections between the power cord and power transformer primary lead wires are performed using crimp type connectors, if replacing the connectors is unavoidable, in order to prevent safety hazards, perform carefully and precisely according to the following steps.

1) **Connector part number** : E03830-001

2) **Required tool** : Connector crimping tool of the proper type which will not damage insulated parts.

3) **Replacement procedure**

(1) Remove the old connector by cutting the wires at a point close to the connector.

Important : Do not reuse a connector (discard it).

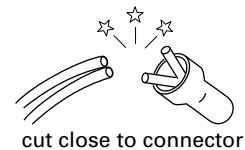

cut close to connector

Fig.3

(2) Strip about 15 mm of the insulation from the ends of the wires. If the wires are stranded, twist the strands to avoid frayed conductors.

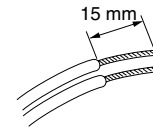

Fig.4

(3) Align the lengths of the wires to be connected. Insert the wires fully into the connector.

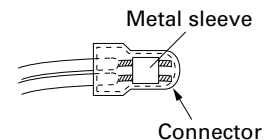

Fig.5

(4) As shown in Fig.6, use the crimping tool to crimp the metal sleeve at the center position. Be sure to crimp fully to the complete closure of the tool.

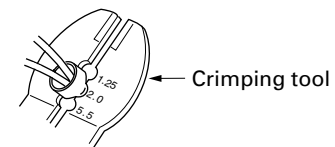

Fig.6

(5) Check the four points noted in Fig.7.

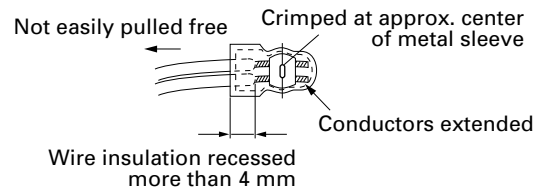

Fig.7

● Safety Check after Servicing

Examine the area surrounding the repaired location for damage or deterioration. Observe that screws, parts and wires have been returned to original positions. Afterwards, perform the following tests and confirm the specified values in order to verify compliance with safety standards.

1. Insulation resistance test

Confirm the specified insulation resistance or greater between power cord plug prongs and externally exposed parts of the set (RF terminals, antenna terminals, video and audio input and output terminals, microphone jacks, earphone jacks, etc.). See table 1 below.

2. Dielectric strength test

Confirm specified dielectric strength or greater between power cord plug prongs and exposed accessible parts of the set (RF terminals, antenna terminals, video and audio input and output terminals, microphone jacks, earphone jacks, etc.). See table 1 below.

3. Clearance distance

When replacing primary circuit components, confirm specified clearance distance (d), (d') between soldered terminals, and between terminals and surrounding metallic parts. See table 1 below.

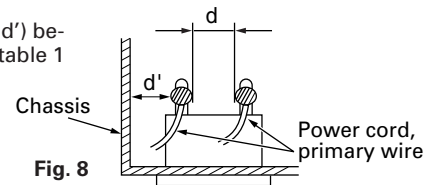

4. Leakage current test

Confirm specified or lower leakage current between earth ground/power cord plug prongs and externally exposed accessible parts (RF terminals, antenna terminals, video and audio input and output terminals, microphone jacks, earphone jacks, etc.).

Measuring Method : (Power ON)

Insert load Z between earth ground/power cord plug prongs and externally exposed accessible parts. Use an AC voltmeter to measure across both terminals of load Z. See figure 9 and following table 2.

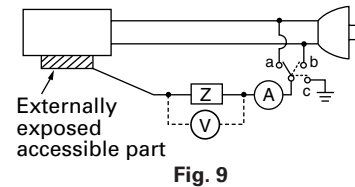

5. Grounding (Class I model only)

Confirm specified or lower grounding impedance between earth pin in AC inlet and externally exposed accessible parts (Video in, Video out, Audio in, Audio out or Fixing screw etc.).

Measuring Method:

Connect milli ohm meter between earth pin in AC inlet and exposed accessible parts. See figure 10 and grounding specifications.

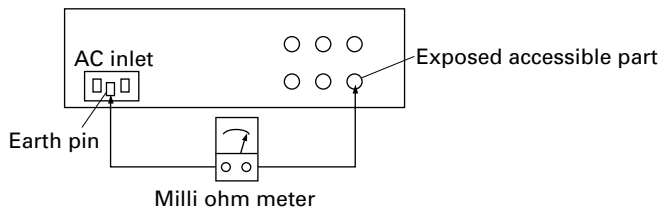

Grounding Specifications

Region	Grounding Impedance (Z)
USA & Canada	$Z \leq 0.1 \text{ ohm}$
Europe & Australia	$Z \leq 0.5 \text{ ohm}$

AC Line Voltage	Region	Insulation Resistance (R)	Dielectric Strength	Clearance Distance (d), (d')
100 V	Japan	$R \geq 1 \text{ M}\Omega/500 \text{ V DC}$	AC 1 kV 1 minute	$d, d' \geq 3 \text{ mm}$
100 to 240 V			AC 1.5 kV 1 minute	$d, d' \geq 4 \text{ mm}$
110 to 130 V	USA & Canada	-	AC 900 V 1 minute	$d, d' \geq 3.2 \text{ mm}$
110 to 130 V 200 to 240 V	Europe & Australia	$R \geq 10 \text{ M}\Omega/500 \text{ V DC}$	AC 3 kV 1 minute (Class II) AC 1.5 kV 1 minute (Class I)	$d \geq 4 \text{ mm}$ $d' \geq 8 \text{ mm}$ (Power cord) $d' \geq 6 \text{ mm}$ (Primary wire)

Table 1 Specifications for each region

AC Line Voltage	Region	Load Z	Leakage Current (i)	a, b, c
100 V	Japan	$1 \text{ k}\Omega$	$i \leq 1 \text{ mA rms}$	Exposed accessible parts
110 to 130 V	USA & Canada	$0.15 \mu\text{F}$ and $1.5 \text{ k}\Omega$	$i \leq 0.5 \text{ mA rms}$	Exposed accessible parts
110 to 130 V 220 to 240 V	Europe & Australia	$2 \text{ k}\Omega$	$i \leq 0.7 \text{ mA peak}$ $i \leq 2 \text{ mA dc}$	Antenna earth terminals
		$50 \text{ k}\Omega$	$i \leq 0.7 \text{ mA peak}$ $i \leq 2 \text{ mA dc}$	Other terminals

Table 2 Leakage current specifications for each region

Note: These tables are unofficial and for reference only. Be sure to confirm the precise values for your particular country and locality.

SECTION 1 CIRCUIT BOARD COMPATIBILITY

Model Unit Name	MC-8100LU	MC-8200LU/8600LU	MC-8100	MC-8200/8600	MC-7100	MC-7200/7600	MC-2100	MC-2200/2200P MC-2600/2600P	MC-1200/1600
SCSI PCB ASS'Y	MC81-SCSI	MC82-SCSI	MC81-SCSI	MC82-SCSI	MC71-SCSI	MC72-SCSI	MC21-SCSI	MC22-SCSI	MC12-SCSI
CHASSIS PCB ASS'Y	MC81-CHAS	MC82-CHAS	MC81-CHAS	MC82-CHAS	MC71-CHAS	MC72-CHAS	MC21-CHAS	MC22-CHAS	MC12-CHAS
CARRIER MECHA ASS'Y	MC21-CARR	MC22-CARR	MC21-CARR	MC22-CARR	MC21-CARR	MC22-CARR	MC21-CARR	MC22-CARR	MC12-CARR
MAIL SLOT ASS'Y	MC12-MAIL								
U/D MOTOR ASS'Y	MC21-UD-M	MC12-UD-M	MC21-UD-M	MC12-UD-M	MC21-UD-M	MC12-UD-M	MC21-UD-M	MC12-UD-M	MC12-UD-M
MAGAZINE SET	MC-M25 (B)				MC-M25		MC-M15		
POWER UNIT ASS'Y	QALD141-001	QAL0538-001	QAL0141-001	QAL0112-001	QAL0141-001	QAL0112-001	QAL0141-001	QAL0112-001	MC12-POWR
CD-ROM DRIVE	—	—	MC-D32/MC-D18		—	—	MC-D32/MC-D18		
CD-R DRIVE	—	—	MC-R18/MC-R14/MC-R12		—	—	MC-R18/MC-R14/MC-R12		
DVD-ROM DRIVE	—	—	MC-D307/MC-D104/MC-D207		—	—	MC-D307/MC-D104/MC-D207		
DVD-RAM DRIVE	—	—	MC-R400/MC-R200		MC-R200		—	—	—
DVD-R DRIVE	—	—	MC-R421	MC-R421	—	—	—	—	—
DVD-RAM/R DRIVE	MC-R434	MC-R434	MC-R433	MC-R433	—	—	—	—	—

*1: The CARRIER MECHA ASS'Y has upward compatibility. (The MC21-CARR can be used with all models.)

SCSI PCB Compatibility Table

○: Usable. △: Usable by replacing ROM. ×: Unusable.

	MC-8100LU	MC-8200LU/8600LU	MC-8100	MC-8200/8600	MC-7100	MC-7200/7600	MC-2100	MC-2200/2600	MC-1200/1600
MC81-SCSI	○	×	○	×	△	×	△	×	×
MC82-SCSI	×	○	×	○	×	△	×	△	×
MC71-SCSI	△	×	△	×	○	×	△	×	×
MC72-SCSI	×	△	×	△	×	○	×	△	×
MC21-SCSI	△	×	△	×	△	×	○	×	×
MC22-SCSI	×	△	×	△	×	△	×	○	×
MC12-SCSI	×	×	×	×	×	×	×	×	○

CHASSIS PCB Compatibility Table

○: Usable. △: Usable by replacing ROM. ×: Unusable.

	MC-8100LU	MC-8200LU/8600LU	MC-8100	MC-8200/8600	MC-7100	MC-7200/7600	MC-2100	MC-2200/2600	MC-1200/1600
MC81-CHAS	○	×	○	×	△	×	△	×	×
MC82-CHAS	×	○	×	○	×	×	×	×	×
MC71-CHAS	△	×	△	×	○	×	△	×	×
MC72-CHAS	×	×	×	×	×	○	×	△	△
MC21-CHAS	△	×	△	×	△	×	○	×	×
MC22-CHAS	×	×	×	×	×	△	×	○	△
MC12-CHAS	×	×	×	×	×	△	×	△	○

CARRIER MECHA ASS'Y Compatibility Table

○: Usable. ×: Unusable.

	MC-8100LU	MC-8200LU/8600LU	MC-8100	MC-8200/8600	MC-7100	MC-7200/7600	MC-2100	MC-2200/2600	MC-1200/1600
MC21-MCRR	○	○	○	○	○	○	○	○	○
MC22-MCRR	×	○	×	○	×	○	×	○	○
MC12-MCRR	×	×	×	×	×	×	×	×	○
MC-CF10	○	○	○	○	×	×	×	×	×

SECTION 2

PRODUCT SPECIFIC SERVICE ITEMS

2.1 Removal of Major Parts

2.1.1 Replacement of Fuses and Batteries

1. Fuses

Note:

Perform fuse replacements correctly.
Never use a fuse other than that specified by the manufacturer (same model number or its equivalent).

There are two fuses on the chassis PCB and one fuse on the SCSI PCB. When replacing a fuse, be sure to use one having the specified parts number. For the parts number, refer to "5.ELECTRICAL PARTS LIST".

Chassis PCB : F2, F3

SCSI PCB : F2

2. Batteries

Note:

If the battery is not replaced correctly, it could cause an explosion.
Never use a battery other than one specified by the manufacturer (same model number or its equivalent). After replacement, dispose of the expired battery according to the instructions of the manufacturer.

There are two batteries; one on the chassis PCB and the other on the SCSI PCB. When replacing a battery, be sure to use one having the specified parts number. For the parts number, refer to "5. ELECTRICAL PARTS LIST".

Chassis PCB : BT1

SCSI PCB : BT1

2.1.2 Opening/Closing the Door and Panel Removal

Opening the Door

<In normal condition>

1. In the normal display mode, press the MODE key.
(The menu display appears.)
2. Press the SELECT key 4 times.
("5. DOOR OPEN MODE" appears.)
3. Press the ENTER key.
(Select "5. DOOR OPEN MODE".)
4. Press and hold the SELECT key for more than 5 seconds.
(Wait until the display starts to blink.)
5. Release the SELECT key when the execution display appears.
*When installing/removing drive units, turn off the power after the completion display appears.
6. Insert the door key in the cylinder and turn it counterclockwise to release the lock and open the door.

1 . NORMAL DISPLAY
2 . ERROR DISPLAY

5 . DOOR OPEN MODE
6 . ID No . SET MODE

PUSH SELECT KEY
TO OPEN THE DOOR

PUSH SELECT KEY
TO OPEN THE DOOR

EXECUTING DOOR
OPEN PROCESS

THE DOOR
CAN BE OPENED

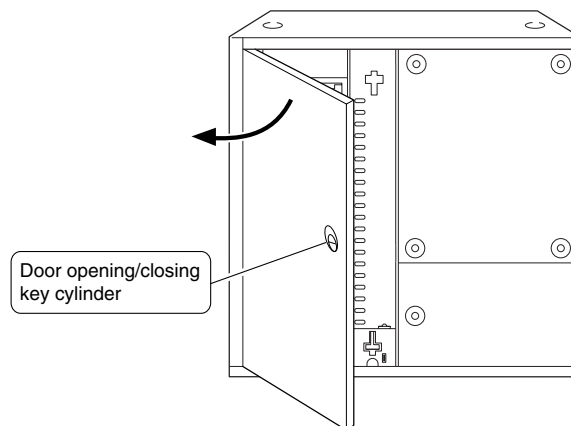
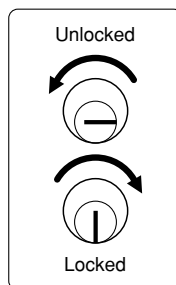

<When trouble occurs>

When the power is not turned on or when electrical or mechanical trouble occurs, the unit will not enter the door open mode with the above operations, and inserting the key cannot open the door. In this case, proceed in the following manner to open the door.

1. Turn the power of the main unit to OFF.
2. Insert a pin having a diameter of approx. 2 mm (or extended spike or clip, etc.) into the emergency hole to release the key lock. With this, you can turn the key to perform the door opening operation.

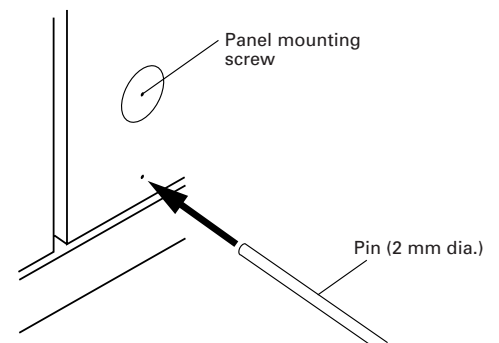
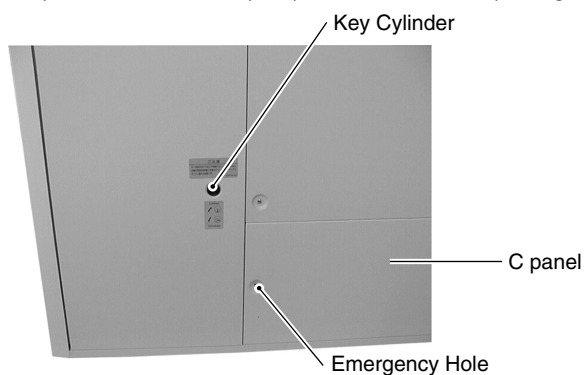

Removing the C-Panel (Printer Panel)

<In normal condition>

When the power of the main unit is OFF, first turn it ON. In most cases, the panel of the printer storage section is not locked. However, depending on the operation when the power is turned OFF, the carrier may be located in the lower section. In this case, since the panel is locked for protection, perform the operation in the same way as described in "Opening the door <In normal condition>" to show the MENU display and perform "4. PANEL OPEN" operation.

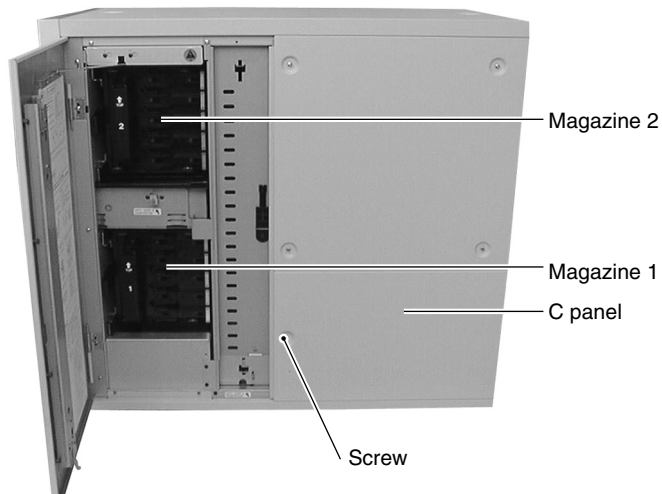

Removing the C-Panel (Printer Panel)

<In abnormal conditions>

Normally the lock is released in the panel-open mode. When the carrier stops at the lower position and an abnormal condition occurs, first remove the magazine-1 and magazine-2 (refer to 2.1.3), hold the chassis section of the carrier mechanism ass'y and lift the carrier mechanism to the lock release position.

2.1.3 Removing the Magazine

1. Open the door. (Refer to 2.1.2.)



2. Pull the release lever which locks the magazine toward you. The magazine is slightly protruded toward the front.

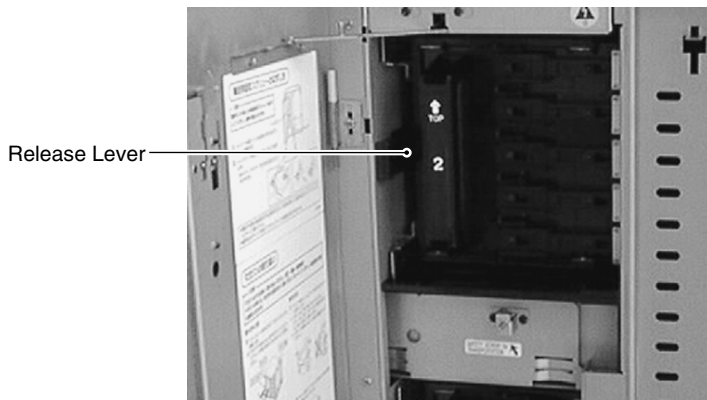

3. Grasp the grip to remove the magazine toward you.

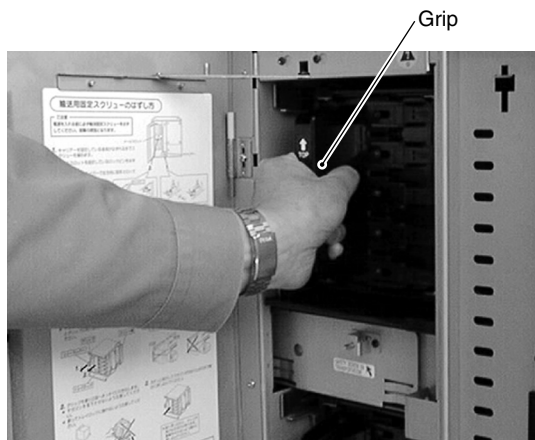

4. When loading the magazine, insert the magazine gently until it clicks.

2.1.4 Removing the Drive

1. Open the door. (Refer to 2.1.2.)
2. Remove the side cover (R). (Refer to 2.1.8.)
3. Remove the rear panel. (Refer to 2.1.9.)
4. Disconnect the two connector cables from the drive.
5. Disconnect all the SCSI cables from all the drives and the SCSI PCB. (When removing the drive in the uppermost slot among the currently mounted drives, disconnect the cable connected to the uppermost drive only.)

Photo shows situation when removing the Drive 2



SCSI cable

Connector cable

6. Remove the screw ① located on the side of the drive (door panel side).

Photo shows situation when removing the Drive 2

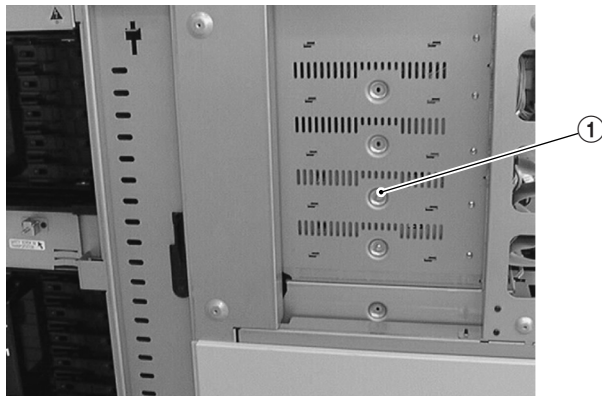

7. Remove the drive from the rear.

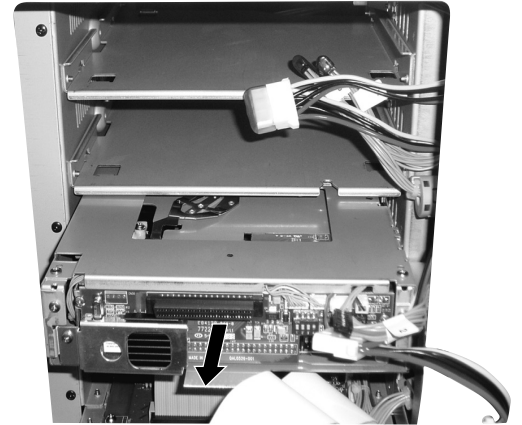

2.1.5 Removing the side stay R

1. Open the door. (Refer to 2.1.2.)
2. Remove the C panel. (Refer to 2.1.2.)
3. Remove the side cover R. (Refer to 2.1.8.)
4. Remove the four screws ② to remove the side stay R.

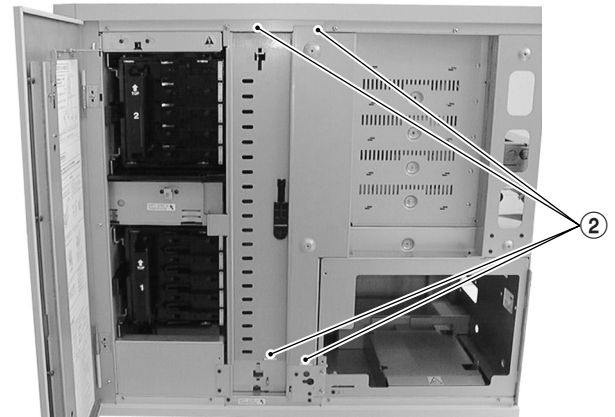

Note:

Side stay R must be removed when removing the carrier mechanism.

2.1.6 Removing the Carrier Mechanism

1. Open the door. (Refer to 2.1.2.)
2. Remove the side stay R. (Refer to 2.1.5.)
3. Remove the #1 and #2 magazines. (Refer to 2.1.3.)

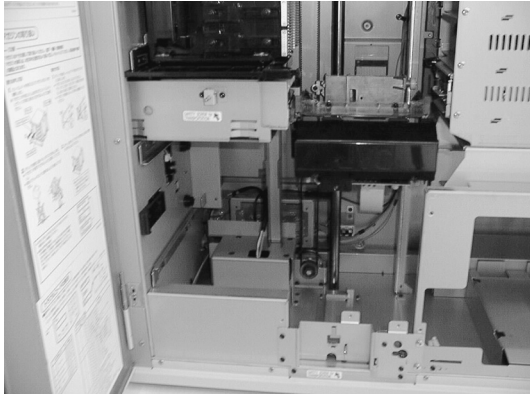

6. Remove the carrier mechanism upward.
7. Turn the carrier mechanism upside down, and remove a screw (4) retaining the flat cable mounting bracket.

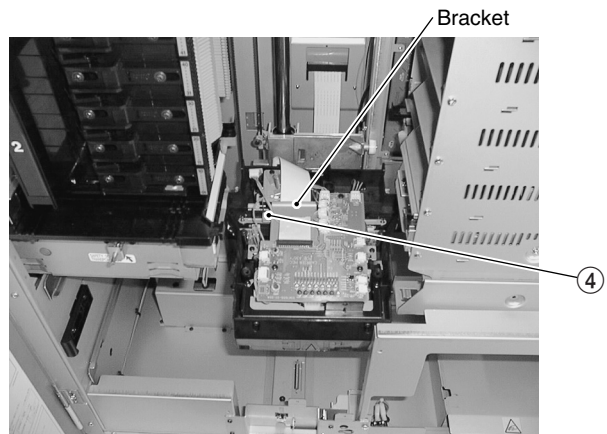

4. Remove the three screws (3).

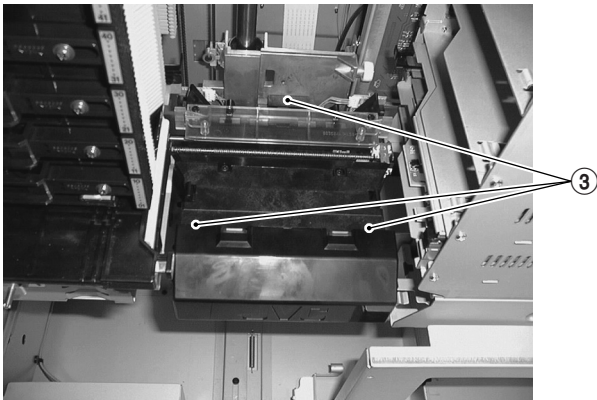

8. Release the flat cable connector lock and disconnect the flat cable to remove the carrier mechanism.

Note:

Pay attention not to damage the lock of the flat cable connector

5. Hold the carrier mechanism by the bottom ass'y and move it to a position approx. 5 cm lower than the mail slot. (Pay attention during this operation because the carrier mechanism is very heavy.)

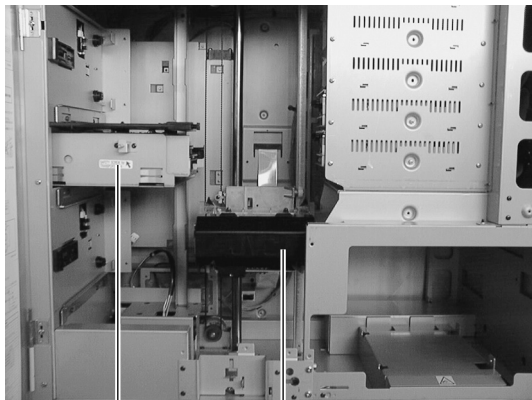

Mail slot

Carrier mechanism

2.1.7 Removing the Side Panel L

1. Remove the eight screws ⑤ to remove the side panel. When removing the side panel, unscrew while holding the side panel with your hands. (To prevent the panel from dropping.)

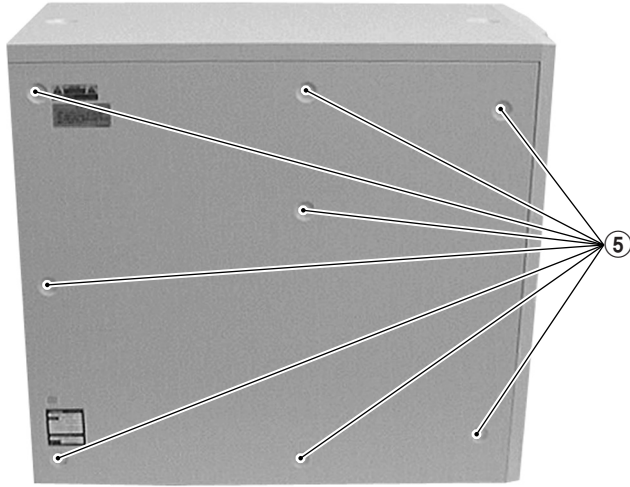

2.1.9 Removing the Rear Panel

1. Remove the six screws ⑦.



2.1.8 Removing the Side Panel R

1. Open the door. (Refer to 2.1.2).
2. Remove the four screws ⑥.

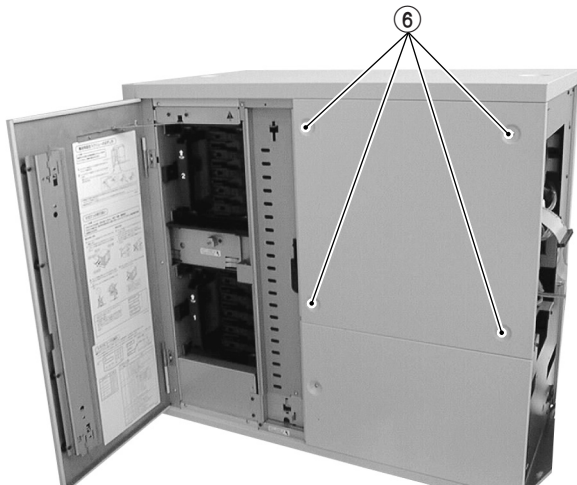

2.1.10 Removing the Power Supply Unit

1. Remove the side panel L. (Refer to 2.1.7.)
2. Disconnect the connector cables connected to the power supply unit.

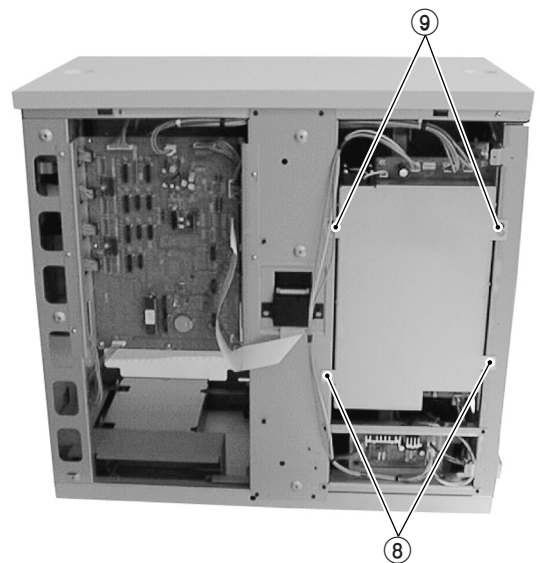

3. Remove the two screws ⑧.
4. Slightly loosen the two screws ⑨, and remove the power supply unit by sliding it upward.

2.1.11 Removing the Chassis PCB

1. Remove the rear panel. (Refer to 2.1.9.)
2. Remove the side panel L. (Refer to 2.1.7.)
3. Remove the chassis PCB and connector cables from the drive at the drive side. (Leave the cables connected to the drive power supply as they are.)

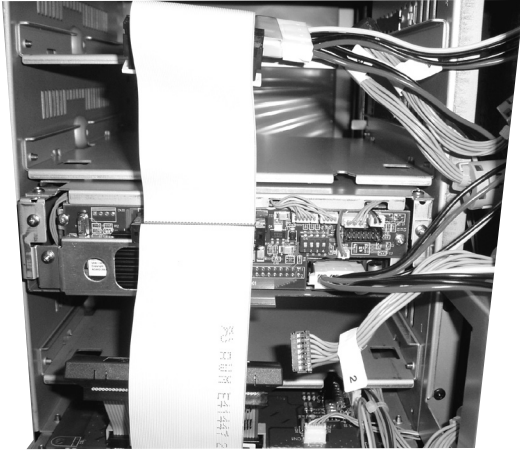

4. Disconnect the connector cables from the chassis PCB.
5. Remove the four screws ⑩.

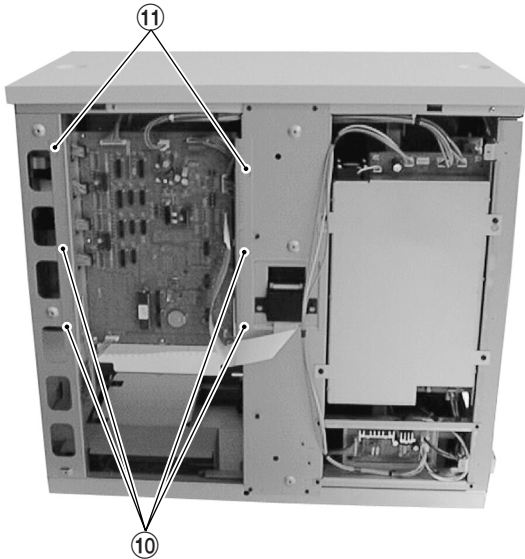

6. Loosen the two screw ⑪, and pull the chassis PCB out by sliding it upward.

2.1.12 Removing the SCSI PCB

1. Remove the rear panel. (Refer to 2.1.9.)
2. Disconnect the two connector cables and all the SCSI cables connected to the SCSI PCB and the drives.

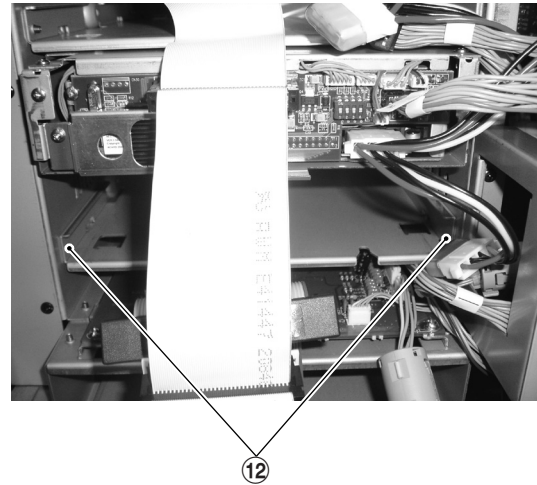

3. Remove the two screws ⑫ and pull the SCSI PCB toward you until the connector at the right sides are exposed, then disconnect the two connectors from the chassis side.
4. Remove the SCSI PCB by pulling it toward you.
5. When installing the SCSI board, insert it until the end of the board is securely held in the groove.



2.1.13 Removing the Mail Slot

1. Open the door. (Refer to 2.1.2.)
2. Remove the side panel L. (Refer to 2.1.7.)
3. Remove the power supply unit. (Refer to 2.1.10.)
4. Remove the #1 magazine. (Refer to 2.1.3.)
5. Insert your hand into the #1 slot and gently push the tray of the mail slot. Pay attention not to push the tray forcibly for it could damage the gear teeth.



6. Gently pull out the mail slot tray toward you and push the guide to the main unit side. Remove a screw ⑬ and pull out the mail slot panel by sliding it toward the left.

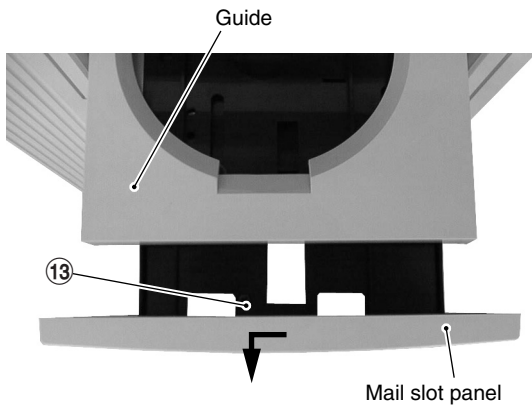

7. Remove the six screws ⑭ to remove the front panel of the main unit.

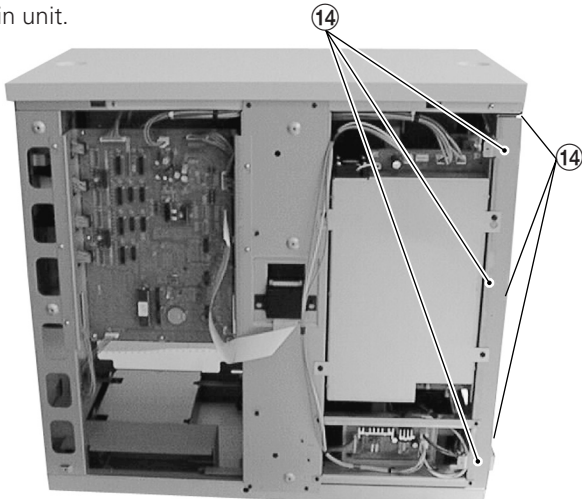

8. Disconnect the connector cable on the mail CN PCB, and remove the two screws ⑮.

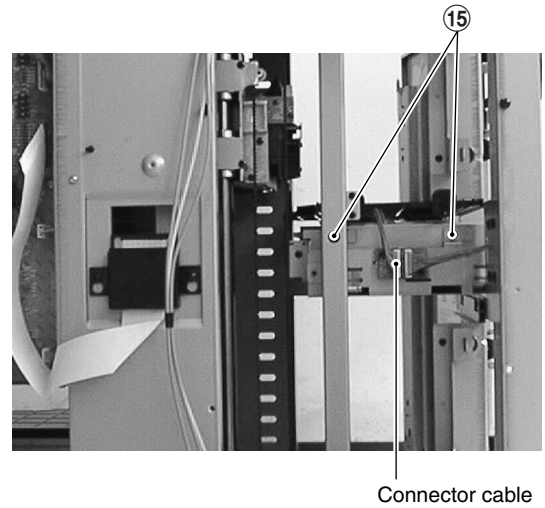

9. Remove the mail slot from the front of the main unit.



2.1.14 Removing the Top Panel

1. Open the door. (Refer to 2.1.2.)
2. Remove the side panel L. (Refer to 2.1.7.)
3. Remove the side panel R. (Refer to 2.1.8.)
5. Remove the two blind bolts ⑯ using a coin, etc.
6. Remove the five screws ⑰ to remove the top panel.

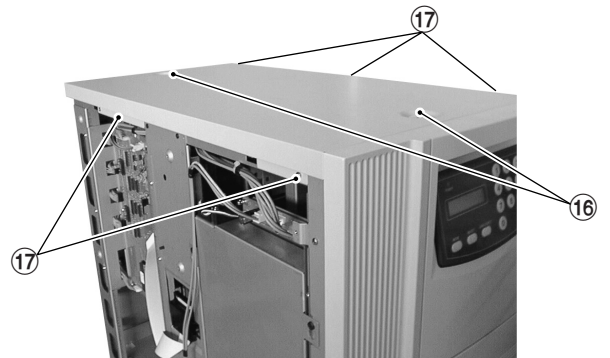

2.1.15 Removing the U/D Motor

1. Remove the carrier mechanism. (Refer to 2.1.6.)
2. Remove the power supply unit. (Refer to 2.1.10.)
3. Remove the mail slot. (Refer to 2.1.13.)
4. Remove the screws ⑱, ⑲ and ⑳ of the magazine stay, then remove the connector from the U/D mechanism ass'y.

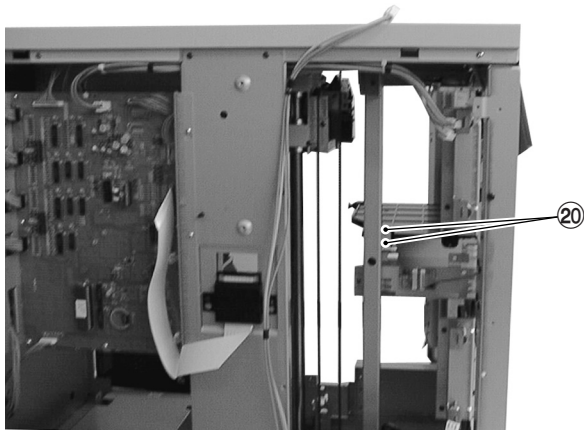
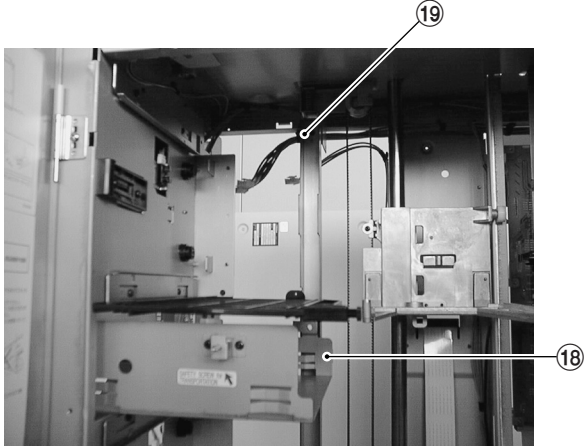

5. Remove the screw ㉑ of the motor cover, then remove the magazine stay and the motor cover.

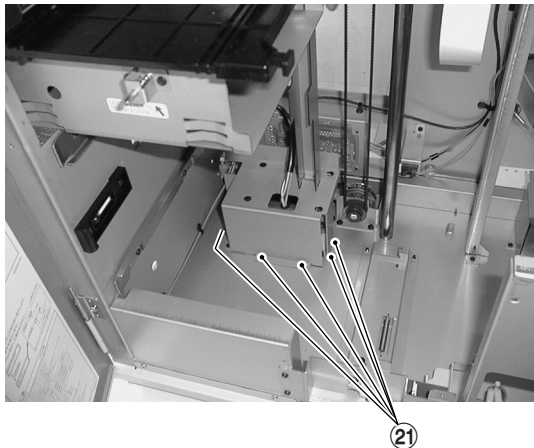

6. Remove the screw ㉒ of the U/D mechanism ass'y and the screw ㉓ of the pulley unit. At this time, be sure to hold the carrier base by hand. (Otherwise, the carrier mechanism may be dropped.)

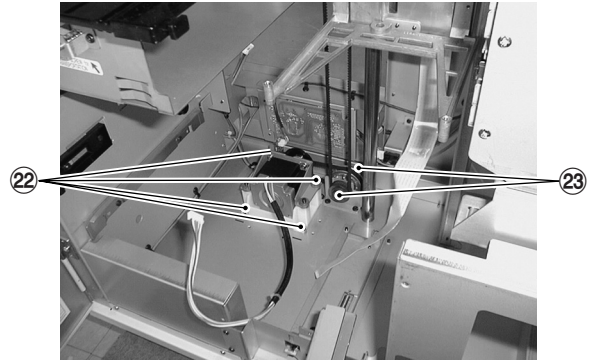

Remove the belt to pull out the U/D ass'y and the pulley unit, and remove the sensor of the U/D ass'y. Then remove the belt between the U/D ass'y and the pulley unit.

2.1.16 How to Operate with the Door Open (for Servicing)

For safety this unit is designed so as not to be operated with the door open. When operating the unit with the door open for maintenance or servicing, proceed in the following manner.

1. Open the door. (Refer to 2.1.2.)
2. Remove an interlock release bar on the center panel which turns the interlock switch to ON.

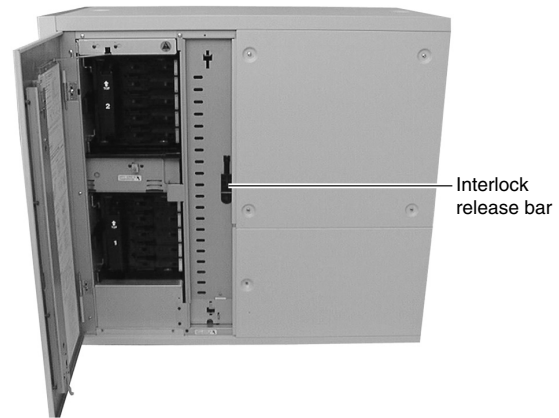

3. With the door open, insert an interlock release bar into the interlock switch hole located at the left side.

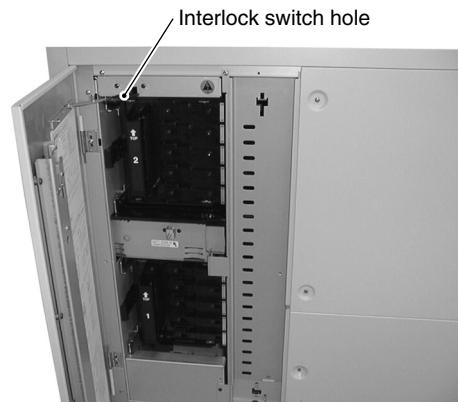

4. With this operation, the unit enters the mode in the same way as with the door closed, and you can operate the unit as normally.

2.2 Special Operation Mode

• Operating Condition

The external control equipment must not be connected to the SCSI connector. (That is the CD/DVD Library is not operated as a part of the system.) If the special operation mode is activated in the system operating condition, the correct operation will not be guaranteed.

• Mode Setting

As shown in the table below, the operation mode is determined depending on the status of each switch at the moment when the CD/DVD Library's power is turned ON.

("-" in the table below is the conventional symbol for OFF.)

M: Mode S: Select L/E: Load/Eject E: Enter 0-9: Numeric keypad

SW Status												Operation Mode	Page
M	S	L/E	E	0	1	2	3	4	5	8	9		
—	—	—	—	—	—	—	—	—	—	—	—	Normal mode	—
—	—	—	—	—	ON	—	—	—	—	—	—	Package mode	2-14
—	—	—	—	—	—	ON	—	—	—	—	—	Disc return mode	2-14
—	—	—	—	—	—	—	ON	—	—	—	—	Memory clear mode	2-14
—	—	—	—	—	ON	—	—	ON	—	—	—	Auto check mode	2-15
ON	—	ON	—	—	—	—	—	—	—	—	—	Disc tray check mode	2-15
—	ON	ON	—	—	—	—	—	—	—	—	—	Auto tray check ON/OFF switching	2-16
Running modes for use in factory production. Cannot be used in servicing.												Running mode (5) (Production running)	
												Running mode (1) (Mechanism running)	
—	—	—	ON	—	—	—	ON	—	—	—	—	Running mode (3) (Demonstration running)	2-11
—	—	—	ON	—	—	—	—	ON	—	—	—	Running mode (4) (Upper/lower limit check)	2-11
—	—	—	ON	—	—	—	—	—	—	—	ON	Manual mode	2-12
—	—	—	—	—	—	—	—	—	—	ON	—	Drive detection mode	2-15

Other than the above, a self-check mode for use during maintenance is also available (by turning the power ON while pressing the MODE key).

- * In the Disc Return, Memory Clear, Disc Tray Check or Auto Tray Check ON/OFF Select mode, the CD-ROM Library operates in the normal mode after the corresponding operation is completed.
- * Since each operation mode other than normal mode (including Disc Return, Memory Clear, Disc Tray Check and Auto Tray Check ON/OFF Select modes) is performed with the door open, the interlock release lever must be inserted into the interlock switch hole. (Each of the mode will not operate correctly with the door open but without the interlock release bar because the 15V power is turned OFF.)
- * Also if the printer panel is open, the 15V power is OFF and the Library operation is not available.)

2.2.1 Running Modes

1. Details of Running

- * During running mode, the "RUNNING MODE" warning and the number of times appear on the LCD display. During demonstration mode, the "DEMONSTRATION MODE" warning and the number of times appear.
- * All the magazines must be installed. (However the demonstration mode automatically detects the presence of magazines, and only the installed magazines are accessed.)

① Demonstration Mode

(1) Purpose

This mode is used to perform a demonstration of the CD/DVD changer operation.

(2) Start

While pressing the "ENTER" key and the numeric key "3" simultaneously, turn the power ON.

* It is not necessary to set the discs on each tray. (A disc presence check is not performed.)

(3) Operation

Repetition of crossing operation.

Disc Access (MC-8100U: when drives 1 and 2 are connected)

• Crossing Operation

Count	Access Address
0001	"100" → DR1 → "100"
0002	"001" → DR2 → "001"
0003	"099" → Mail slot → "099"
0004	"002" → DR1 → "002"
0005	"098" → DR2 → "098"
0006	"003" → Mail slot → "003"
0099	"051" → Mail slot → "051"
0100	"050" → DR1 → "050"

(4) Operation Stop

When the numeric key "3" is pressed during demonstration, the operation stops after the disc being accessed is returned to the original magazine.

(5) Operation Restart

When the "ENTER" key is pressed in the demonstration-stop mode, the operation restarts from the tray next to the one being accessed the previous time.

② Carrier Upper/Lower Limit Check Mode

(1) Purpose

Checks whether the tray loading/ejecting operation is possible or not at the upper and lower limits of the address slits.

(2) Start

While pressing the "ENTER" key and the numeric key "4" simultaneously, turn the power ON.

* It is not necessary to set the discs on each tray. (A disc presence check is not performed.)

(3) Operation

Accesses to the 2nd address from the top (Tray No. 49 in the magazine) and the 2nd address from the bottom (Tray No. 02 in the magazine), drive and the mail slot in order twice for each. Searches for the lower limit at the 1st cycle and for the upper limit at the 2nd cycle as a target.

Operation Sequence (MC-7100U: When drives 1 and 2 are connected)

- 1) Address 99 → Drive 1 → Address 99 (Lower limit)
- 2) Address 52 → Drive 2 → Address 52 (Upper limit)
- 3) Address 49 → Address 49 (Lower limit) (When drive 3 exists: To Drive 3)
- 4) Address 02 → Address 02 (Lower limit) (When drive 4 exists: To Drive 4)
- 5) Address 99 → Address 99 (Lower limit)
- 6) Address 52 → Address 52 (Lower limit)
- 7) Address 49 → Mail Slot → Address 49 (Lower limit)
- 8) Address 02 → Address 02 (Lower limit) (When printer exists: To Printer)
- 9) Checks for upper limit for 1) to 8)

(4) LCD display in upper/lower limit check mode



Tray No. being accessed. However, An "END" warning appears when finished.

(5) During upper/lower limit check mode, the phase difference of the Up/Down rotary encoder is automatically checked and its result is shown on the LCD display.

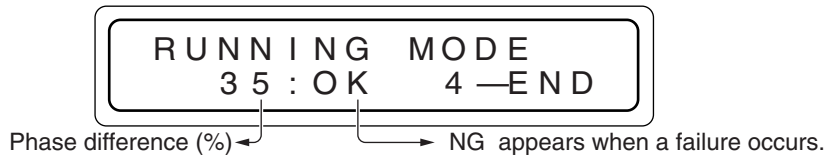

2.2.2 Access Counter Clearance

1. Set to display the contents shown on page 30 of the instruction manual.
2. Hold the SELECT key until the unit to be cleared appears in the 1st line.
3. With the unit counter to be cleared shown on the 1st line, hold the ENTER key for more than 5 seconds.

2.2.3 Manual Operation

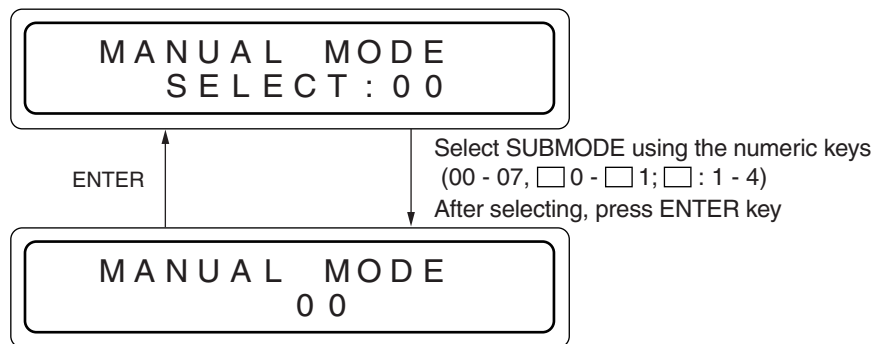

Pressing numeric key 1 - 5 activates the corresponding operation (refer to the table on the this page).

① Carrier Manual Operation

· Carrier upward operation (SUBMODE = 00)

Function	Numeric key	Details
Upward normal move	1	During key is ON (Condition: Tray lock initial position)
Upward low-speed move	2	During key is ON (Condition: Tray lock initial position)
Upward 1-slit move toward left	3	Each time key is ON (Condition: Tray lock initial position)
Upward 1-slit move toward right	4	Each time key is ON (Condition: Tray lock initial position)
Upward 1-step advance	5	Each time key is ON (Condition: Tray lock initial position)

· Carrier downward operation (SUBMODE = 01)

Function	Numeric key	Details
Downward normal move	1	During key ON, until lower limit sensor is reached (Condition: Tray lock initial position)
Downward low-speed move	2	During key ON, until lower limit sensor is reached (Condition: Tray lock initial position)
Downward 1-slit move toward left	3	Each time key is ON (Condition: Tray lock initial position)
Downward 1-slit move toward right	4	Each time key is ON (Condition: Tray lock initial position)
Downward 1-step advance	5	Each time key is ON (Condition: Tray lock initial position)

· Tray lock/release operation (SUBMODE = 02)

Function	Numeric key	Details
Left tray lock release	1	During key ON, until left tray lock is released
Tray lock initial	2	Each time key is ON
Right tray lock release	3	During key ON, until right tray lock is released

· Catcher operation (SUBMODE = 03)

Function	Numeric key	Details
Catcher leftward move	1	During key is ON
Catcher rightward move	2	During key is ON

· Tray pickup/return operation (SUBMODE = 04)

Function	Numeric key	Details
Left tray auto loading	1	Each time key is ON (Condition: Tray lock initial, Catcher position right)
Right tray auto loading	2	Each time key is ON (Condition: Tray lock initial, Catcher position left)
Tray auto return	3	Each time key is ON (Condition: Tray lock initial, Catcher position left or right)

* Left (Right) Tray Auto Loading Operation

1. Catcher moves toward left (right) → 2. Left (right) tray lock release → 3. Tray pickup

* Tray auto return operation

1. Catcher moves toward the direction of the tray lock pin (Tray return) → 2. Tray lock initial When the printer operation is performed, set the disc-in tray on the printer beforehand.

· Mail slot operation (SUBMODE = 05)

Function	Numeric key	Details
Mail slot ejecting	1	During key is ON, until eject position is reached
Mail slot loading	2	During key is ON, until loading position is reached

· Optional printer operation (SUBMODE = 06)

Function	Numeric key	Details
Printer ejecting	1	Each time key is ON, until ejecting position is reached
Printer loading	2	Each time key is ON, until loading position is reached

· Disc inversion operation when an inversion carrier is installed (SUBMODE = 07)

Function	Numeric key	Details
Arm upward movement	1	During key is ON (Condition: Tray lock initial)
Arm downward movement	2	During key is ON (Condition: Tray lock initial)
Disc inversion	3	Every time key is ON (Condition: Tray lock initial)

② Drive Manual Operation

· Clamping & Clamping release operation (SUBMODE = 0) : Drive No. 1 - 4

Function	Numeric key	Details
Drive clamping	1	During key is ON, until clamping position is reached
Drive clamping release	2	Each time key is ON

When the MC-R200U drive is used and the tray is in the drive, the clamping release operation is activated 3.5 seconds later (however, the 1st operation for each drive starts after 7 seconds) the key is turned ON (the motor starts rotating) to wait until the disc revolution stops.

· Play operation (SUBMODE = 1) : Drive No. 1 - 4

Function	Numeric key	Details
Play ON	1	Each time key is ON (Condition: CD-ROM disc must be clamped)
Play OFF	2	Each time key is ON (Condition: CD-ROM disc must be clamped)

2.2.4 Packing Mode

- (1) Purpose:
For shipping the library's main unit, the carrier mechanism is moved to the fixing position located at the lower end of the unit and the drive is clamped.
- (2) Activation:
· While pressing the the key "1" on the 10-key pad, turn the power ON.
- (3) Operation: (when Drives 1 and 2 are connected)
 - ① Performs carrier initial operation.
 - ② Checks whether the tray is left in the mail slot or not. If the tray is left, it is returned to the magazine.
 - ③ Checks whether the tray is left in the drive 1 or not. If the tray is left, it is returned to the magazine.
 - ④ Checks whether the tray is left in the drive 2 or not. If the tray is left, it is returned to the magazine. (The same operation is performed when drives 3 to 4 are installed.)
 - ⑤ When the printer is connected, the unit also checks whether the tray is left in the printer or not. And if the tray is left, it is returned to the magazine.
 - ⑥ Moves the carrier mechanism to the shipping position.
 - ⑦ Performs clamping operation for the drive 1 & 2.
 - ⑧ Operation completed.
- (4) Others
 - "PACKING MODE" appears on the LCD display.
 - Carrier stop position: Set at the point 100-pulse (approx. 15.6 mm) lower than the position where the lower limit sensor is turned from ON to OFF.
 - When the remaining tray detection is performed with the printer connected, and if the remaining tray is found, the tray is returned to the magazine.
 - When the tray remains in the printer, or when the printer-in tray memory remains in the CD/DVD Library, the tray in the printer will be returned after the printer initializing operation is completed. For this reason, the printer power must be turned ON.

2.2.5 Tray Auto Return Mode

- (1) Purpose:
Performs the operation to return the tray which is left in the drive, the mail slot or optional printer.
- (2) Activation:
While pressing the key "2" on the 10-key pad, turn the power ON.
- (3) Operation:
 - ① Performs carrier initial operation.
 - ② Check whether the tray is left in the drive 1 or not. If the tray is left in, it is returned to the memorized magazine.
 - ③ The same operation as ② is performed for drives 2 to 4 respectively.
 - ④ Checks whether the tray is left in the mail slot or not. If the tray is left in, it is returned to the memorized magazine.
 - ⑤ When the printer is connected, the unit also checks whether the tray is left in the printer or not. And if the tray is left in, it is returned to the magazine.
 - ⑥ Operation completed.

2.2.6 Memory Clear Mode

- (1) Purpose:
Clears the backup memory for the mechanism CPU and SCSI CPU, including to reset the disc/tray mapping data and SCSI ID of the main unit, etc.
- (2) Activation:
While pressing the key "3" on the 10-key pad, turn the power ON.
- (3) Operation:
 - ① Performs the tray auto return mode operation.
 - ② Clears the backup memory for the mechanism CPU and SCSI CPU.
 - * Be sure not to turn the power OFF until the mechanism operation is completed because the memory is cleared after the trays left in the drive/mail slot are returned.

(Note) Trouble history and access counter will not be cleared.

2.2.7 Disc/Tray Check Mode

- (1) Purpose:
Checks the presence/absence of the tray/disc in the magazine and stores the information in the CPU as the mapping data.
- (2) Activation:
 - ① While pressing the MODE key and LOAD/EJECT key simultaneously, turn the power ON.
 - ② After the initializing operation is completed, the disc tray check operation starts.
- (3) Operation
 - ① Picks up the tray on the carrier and returns the tray after checking the tray and the disc, sequentially from the address-1.
 - ② Performs the same operation until the last address is reached.

2.2.8 Auto Check Mode

- (1) Purpose:
Simply checks the tray transfer operation for all units.
- (2) Activation:
While pressing the key "1" and "4" on the 10key pad, turn the power to ON.
* It is not necessary to set the disc on the tray. (A disc presence check is not performed)
- (3) Operation:
Accesses to the 2nd address (Tray No. 49 in the magazine) from the top and the 2nd address (Tray No. 02 in the magazine) positions, drive and mail slot positions. When the printer is connected, it also accesses to the printer.

Operation Sequence

(MC-8100 : when drive 1, 2 and printer are connected)

- ① Address 99 → Drive 1 → Address 99
- ② Address 52 → Drive 2 → Address 52
- ③ Address 49 → Mail Slot → Address 49
- ④ Address 2 → Printer → Address 2
- ⑤ Address 99 → Address 99
- ⑥ Address 52 → Address 52
- ⑦ Address 49 → Address 49
- ⑧ Address 2 → Address 2

- (4) Display during auto check mode

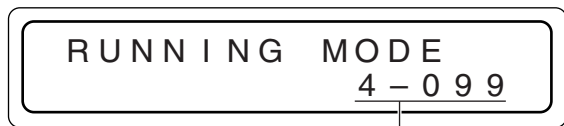

→ Tray No. being accessed. However, "END" appears when finished.

2.2.9 Drive Detection Mode

- (1) Purpose
Drives are detected in order to prevent simultaneous installation of different drives.
- (2) Start
While pressing the "8" key, turn the power ON.
- (3) Operation
After the initial operation, each of the installed drives performs the ejection operation for identification.

LCD display during drive detection



LCD display after drive detection



**Note: Whenever a drive is added, replaced or removed after the last drive detection, be sure to repeat drive detection.
* If this is omitted, a mechanism malfunction may result.**

*** Be sure to turn the power OFF and then ON again after drive detection.**

2.2.10 Auto Disc/Tray Check ON/OFF Setting

This mode selects whether or not the disc in the magazine is automatically checked each time when the magazine is inserted with the power ON.

1. Changing the setting

While pressing the SELECT key and the LOAD/EJECT key located at the side of the LCD, turn the power ON. The operation mode is alternated between ON and OFF. The default setting is ON (auto check function is activated). With the above operation, the setting is changed to OFF (auto check function is deactivated).

2. How to check the current setting

· Hold down the MODE switch beside the LCD for more than 5 seconds. The current setting is displayed on the LCD.

Automatic disc checking function ON



Automatic disc checking function OFF



3. Others

· This setting is maintained after the power is turned off.

2.3 Self-Diagnostic Display

When a trouble occurs, this unit repeats the required process and then stops operation. In case of the trouble on a drive, the defective drive is cut by the host PC and the operation continues with the other drives. When the trouble occurs on all drives, this unit enters the mechanism stop operation. The Indicator blinks when trouble occurs in all cases.)

The trouble codes of the last eight times are stored in the memory and maintained even when the power is turned off.

2.3.1 Displaying Trouble History

(operate with front panel switch to display on the LED)

The history of past errors can be displayed as described below.

- ① In the normal display mode, press the MODE key.
(The menu display appears.)
- ② Press the SELECT key once.
("2. ERROR DISPLAY" appears.)
- ③ Press the ENTER key.
(Select "2. ERROR DISPLAY".)
"NO ERROR FOUND" appears if no error has occurred in the past.
If there is any past error, the data on the latest 8 error occurrences can be recalled from memory and displayed.
- ④ Press the SELECT key to display the data on past errors in sequence.

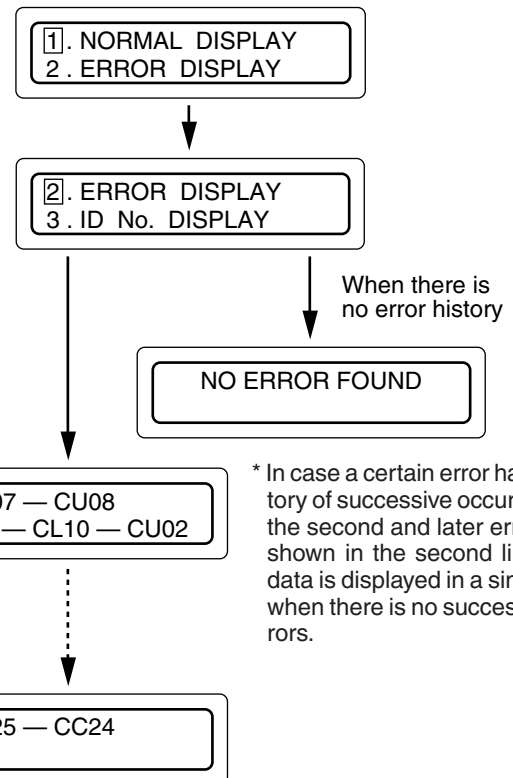
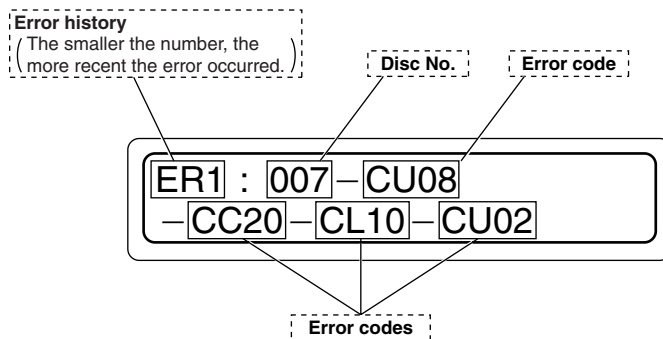

When the following conditions occur, check items listed on the right.

2.3.2 Display When Trouble Occurs

In case of an error, the front panel indicator blinks and the LCD shows the error details by overriding any other information.

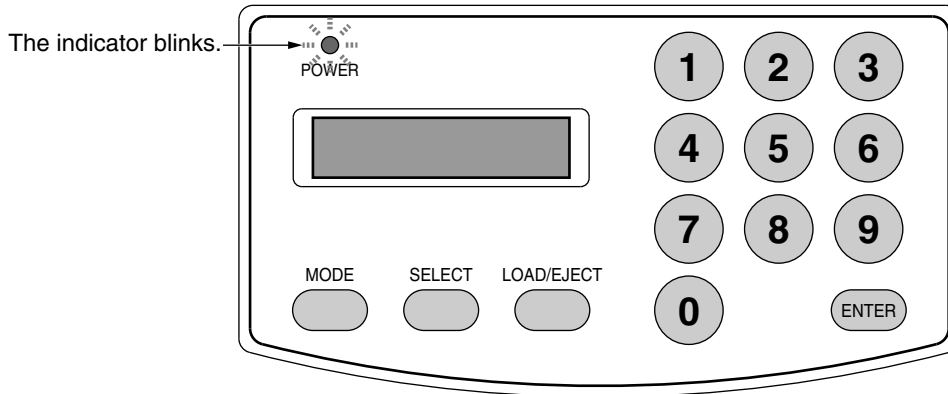

LCD displays in case of error

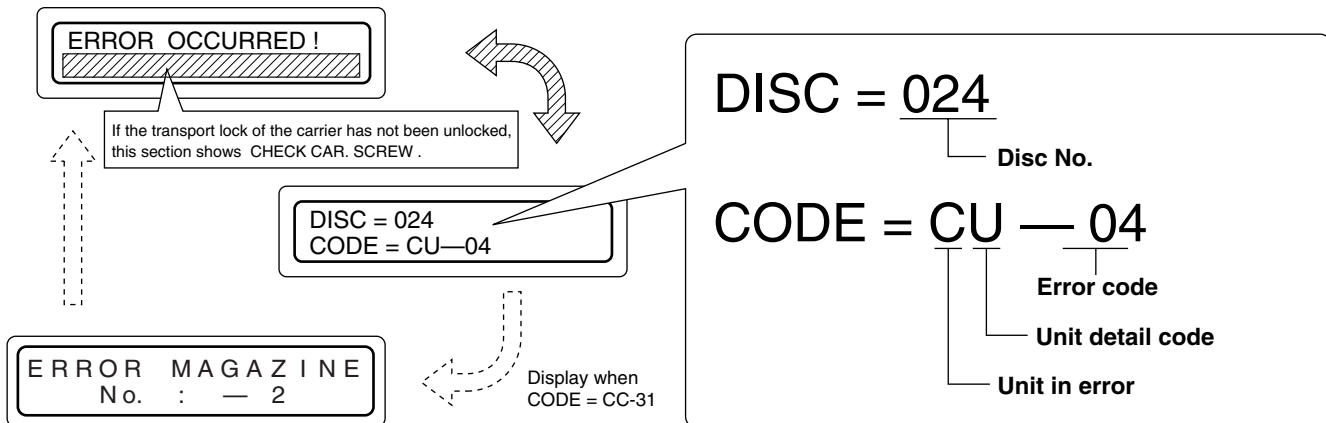

Disc No. : Shows the disc No. being accessed at the moment of error occurrence. "----" is displayed if no disc is accessed at the moment of error occurrence.

Units in error and unit detail codes

Unit in error		Unit detail code	
C	Carrier	U	Up/down
		L	Tray lock
		C	Catcher
		D	Disc
		F	Flip
M	Mail slot	E	Ejection
		L	Loading
		T	Tray
D1 to D4	Drive	T	Tray
		C	Clamp
		E	Ejection
		D	Disc
		S	Spindle
P	Color Disc Printer	T	Tray

2.3.3 Erasing the Trouble History

The error history can be cleared by pressing ENTER key for more than 5 seconds during displayed error history.

2.3.4 Error code list

Device	Device part	Error code	Description
C	U	01	UP/DOWN rotary sensor does not change
		02	Left slit sensor does not change
		03	Right slit sensor does not change
		04	UP/DOWN motor does not function
		05	UP/DOWN motor doesn't work correctly or rotary sensor defective
		08	UP/DOWN operation exceeds the predetermined duration
		09	Upper or lower limit sensor turn on during UP/DOWN operation
C	L	10	Tray lock release not possible
		11	Tray lock impossible, or lane change not possible
		12	Tray lock does not exist at the initial position during carrier movement
C	C	20	Catcher (right → left) movement operation exceeds the predetermined duration
		21	Catcher (left → right) movement operation exceeds the predetermined duration
		22	Catcher (right → left) convergence operation exceeds the predetermined duration
		23	Catcher (left → right) convergence operation exceeds the predetermined duration
		24	Catcher (right → left) tray rotary sensor does not change
		25	Catcher (left → right) tray rotary sensor does not change
		26	Right catcher sensor does not turn on
		27	Left catcher sensor does not turn on
		28	Catcher motor (right → left) does not function
		29	Catcher motor (left → right) does not function
		30	Tray does not exist
C	D	41	Destination-unknown tray exists on the carrier
		42	No disc in the tray
		43	Flip tray does not exist
	F	80	During the flip raise operation, the expected time required is over
		81	During the flip descent operation, the expected time required is over
M	E	50	Mail Slot ejecting is not possible
	L	51	Mail Slot loading is not possible
	T	52	Destination-unknown tray exists in the Mail Slot
(D#) *1	T	60	Destination-unknown tray exists in the Drive and the control cable of the Drive is disconnected.
		61	Tray removal is not possible at the drive position
	C	62	Disc clamp of the drive does not function
	E	63	Drive ejection is not possible
	D	64	Failure to remove the disc from the drive
S	65	Spindle motor fails to stop	
P	T	72	Destination-unknown tray exists in the Label Printer

*1: # represents the drive number.

*2: Check the magazine loading condition.

2.4 Maintenance Mode

2.4.1 Outline

This unit is also equipped with an RS-232C port as an interface for external equipment other than the SCSI interface which is used for connection to the host computer. The RS-232C port is used mainly for the following two purposes:

(a) Remote Maintenance:

It can be used for remote diagnostic operation by connecting to the public telephone line via a modem.

(b) Direct Maintenance:

It can be used for diagnostic operation by direct connection to a computer, etc.

In either way, while this unit is operated in the system the mechanical operation checking, which is one of the checking functions of the self-diagnosis operation, is not available.

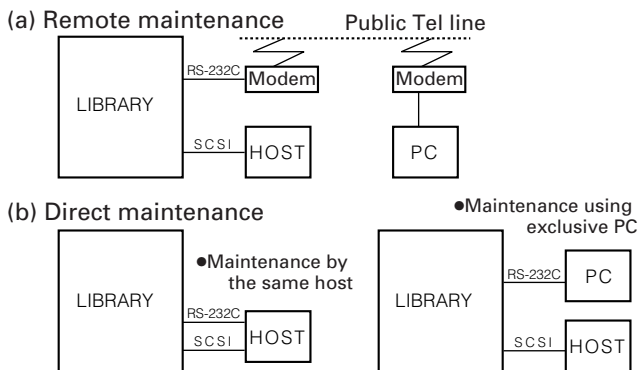

*Judgment whether remote or direct maintenance Checks whether the modem is connected or not when the power is turned ON, and judges the unit is in the "remote maintenance" or "direct maintenance" mode.

The modem control AT command (Z: Reset) is transmitted to the RS-232C port. And if there is a response, the unit is operated as the "remote maintenance" mode, and if there is no response, the unit is operated as the "direct maintenance" mode.

NOTES:

In the "direct maintenance" mode, the host computer must not respond to an AT command.

2.4.2 Electrical Specifications

• Signal Format

Signal Level	RS232C
Communication System	Asynchronous half-duplex
Transfer Rate	9600 bps
Character	Start bit: 1
	Data: 8 bits
	Parity: None
	Stop bit: 1
Codes used	ASCII character code
Modem Control Command	Compliant to Hayes AT command
Compatible Modem	ITU-T V.32

• Connector: D-Sub 9-pin (male)

• Pin Layout

①	DCD (IN)	⑥	DSR
②	RXD (IN)	⑦	RTS (OUT)
③	TXD (OUT)	⑧	CTS (IN)
④	DTR (OUT)	⑨	NC
⑤	S-GND		

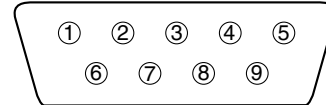

2.4.3 Maintenance Types and Conditions

- ① Operating environment status
Outputs the environmental conditions including the type of this unit (Model No.), status of connected drives, SCSI ID No. setting and ROM version, etc.
- ② Trouble contents check
Outputs the trouble information stored in this unit.
- ③ Self diagnostic function
Performs the preset specific operations and outputs the results as the status. Operations ① and ② are available at any time. The operation ③ is available only when this unit is in the "direct maintenance" mode. Regardless of the currently selected maintenance mode (remote or direct), all the peripheral components must be turned on before turning on the power to this unit.

2.4.4 Activating the Maintenance Mode

To activate the maintenance mode with this unit...

- ① Set the maintenance disc in the address 1 before turning the power ON.
- ② While pressing the MODE switch on the front panel, turn the power switch to ON.

2.4.5 Maintenance Program

To perform maintenance on this unit, the maintenance program software must be installed on the PC connected.

2.5 Maintenance and Periodical Check

The following shows an example of a maintenance reference chart when this unit is used with two drives for 50,000 times a year. Maintenance period differs depending on the using conditions, etc.

Item	Maintenance Intervals						Maintenance Contents
	1yr	2yrs	3yrs	4yrs	5yrs	6yrs	
Carrier	○	○	△	○	○	●	Grease (See Disassembly view.)
U/D Motor Unit	○	○	○	○	○	●	
Mail slot	-	-	-	-	-	○	
Drives	○	○	●	○	○	●	
Air filter unit	-	-	△	-	-	●	Clean filter
Magazine	-	-	△	-	-	△	Clean tray

● : Replacement. △ : Maintenance. ○ : Operation check.

Operation check contents

Item	Check Contents
Carrier	Presence/absence of abnormal sound or backlash, Roller defect/wear, No defect on carrier FCC cable
U/D motor assembly	Presence/absence of abnormal sound or backlash
Mail slot	Presence/absence of abnormal sound or backlash
Drives	Readout speed check using exclusive software
Magazines	Cleaning of tray in the position where frequently used (wipe off dust)

NOTES:

- 1) The maintenance and replacement intervals for the CD/DVD library are variable depending on the operating conditions such as the number of additional optional drives and the frequency of use. It is recommended to replace each drive after every 30,000 disc loading cycles. To check the operation of the CD/DVD drive, perform recording and playback of the exclusively designed CD/DVD disc.
- 2) The service life of the CD/DVD drive is variable depending on the write count (the total time spent in the write mode).
- 3) Each disc carrier tray should be replaced after every operation count of 10,000 cycles.
An operation refers to each operation cycle of the carrier. When the carrier has pulled out a magazine tray, inserted a disc in it and then returned it to its original magazine, the operation count becomes 2.
- 4) When an MC-CF10 optional carrier is used, it is recommended that it should be replaced after 300,000 inversion operations.
The inversion count can be checked as describe in section "11. Access Count" of the instruction manual.

JVC[®]

VICTOR COMPANY OF JAPAN, LIMITED

JVC[®] is a registered Trademark owned by VICTOR COMPANY OF JAPAN, LTD.

JVC[®] is a registered Trademark in Japan, the U.S.A., the U.K. and many other countries.

SECTION 4 EXPLODED VIEW AND PARTS LIST

4.1 FINAL ASSEMBLY M 1

Apply grease (G-31KAV)

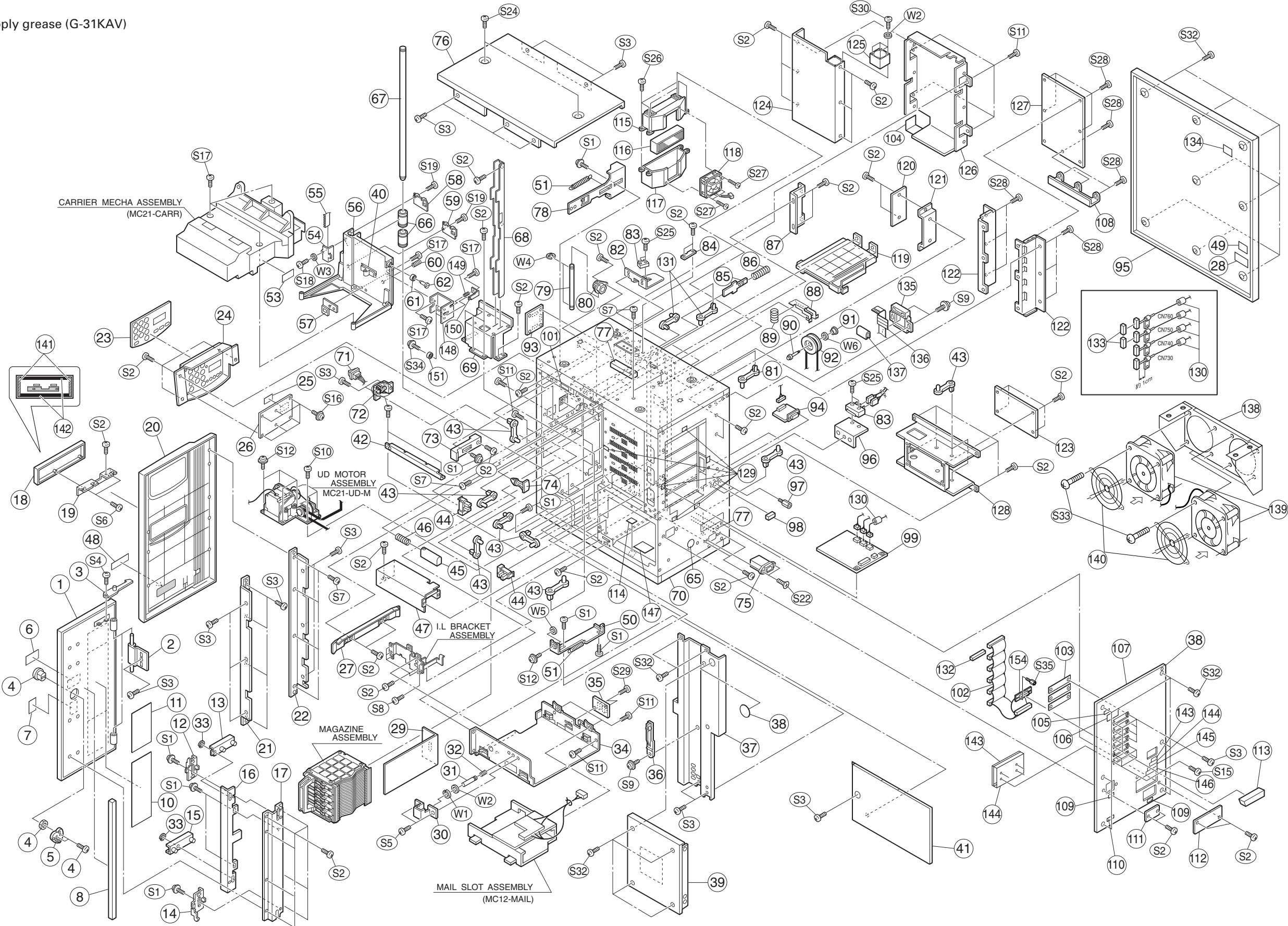

4.2 FINAL ASSEMBLY PARTS LIST 1

1 M M

Symbol No.	Part No.	Part Name	Description
1	SS23024-00B	DOOR PANEL(100)	
2	SS411847-00A	HINGE	
3	SS412126-F0A	STAY	
4	SS32387-00C	LOCK KEY	
5	SS411843-001	CAM	
6	SS412123-001	LABEL	
7	SS412039-001	LABEL	
8	SS411853-D13	SPONGE TAPE	
10	SS35448-003	C.LABEL(TRY/JP)	
11	SS35943	C.LABEL(TPS/JP)	
12	SS35923-003	LOCK HOOK	
13	SS412764-00A	L.LINK ASSEMBLY	
14	SS35924-003	LOCK HOOK 2	
15	SS412764-00B	L.LINK ASSEMBLY	
16	SS35922	BAR	
17	SS35921-00A	BASE ASSEMBLY	
18	SS22744-002	FRONT PANEL	
19	SS411931	BRACKET	
20	SS11739-002	MAIN PANEL	
21	SS35915	FP BRACKET(R)	
22	SS35916	FP BRACKET(L)	
23	SS35914	SWITCH SHEET	
24	SS11732	C.PANEL	
25	SS412759	PROTECTOR	
26	SSK1654-02-00A	DISPLAY BOARD ASSEMBLY	
27	SS35442-001	GUIDE RAIL	
28	SS412562-001	RATING LABEL	
29	SS35824-00A	PROTECTOR	
30	SS411961	BRACKET	
31	SS411959-002	SHAFT	
32	SS411923-002	SPRING	
33	WDL260550-2	S.WASHER	
34	SS11629	BASE	
35	SSK1654-03-00A	MAIL CL BOARD ASSEMBLY	
36	SS412139-001	BAR	
37	SS23021-002	SIDE STAY(R)	
38	SS412043-001	CAUTION LABEL	
39	SS23022	SIDE PANEL(R)	
40	SS413570	C.B Block	
41	SS35994-00A	C.PANEL(RRB)	
42	SS35917	AC BARRIER 2	
43	SS411880-003	CLAMP	
44	GP1A61LC	IC	
45	SS35341-001	LOCK PIN	
46	SS412036-002	SPRING	
47	SS35918	AC BARRIER	
48	SS411842-010	PLATE	
49	SS412047-001	LABEL	
50	SS35439-001	HOOK	
51	SS411085-001	SPRING	
52	SS412044-001	LABEL	
53	SM3921-001	BLANK LABEL	
54	SS410963	BELT HOLDER	
55	SSV2728	BELT	
56	SS35236-00D	CARRIER BASE ASSEMBLY	
57	SS413651	T.BRACKET	
58	SS411639-001	BEARING HOLDER	
59	SS411639-002	BEARING HOLDER	
60	SS410961-001	SPRING	

4.2 FINAL ASSEMBLY PARTS LIST M 1

Symbol No.	Part No.	Part Name	Description
61	SS410958-00A	ROLLER(BEARING)	
62	SS410270	R.SHAFT	
63	SS410955-00A	R.BRACKET ASSEMBLY	
64	SS410960	BR-SCREW	
65	SS412043-001	CAUTION LABEL	
66	SS411638-001	L.B.BEARING	
67	SS412757	GUIDE SHAFT	
68	SS35925-002	MAGAZINE STAY	
69	SS35926	MOTOR COVER	
70	SS35909-00B	CABINET+DRIVE-H	
△ 71	QSW0520-001	POWER SWITCH	AC250V 10A
72	SS412758	P.S BRACKET	
73	SS35340-002	KNOB	
74	SS411149-006	HOLDER	
△ 75	QNC0048-001	AC INLET	AC250V 6A
76	SS11740	C-PANEL(T)	
77	SS412012-T04	CUSHION	
78	SS35443-001	SLIDE BAR	
79	SS412035-001	SHAFT	
80	SS35342-002	HOLDER	
81	SS411880-006	WIRE CLAMP	
82	SS412125-001	IL RULER	
83	QSW0540-001	MICRO SWITCH	
84	SS48933-001	STOPPER	
85	SS412022-001	BAR	
86	SS412036-003	SPRING	
87	SS412025-001	BASE	
88	SS411882	HOLDER	
89	SS411884-002	SPRING	
90	SS48947-002	SHAFT PIN	
91	SS412181	BUSHING	
92	SSV3334	PULLEY ASSEMBLY	
93	SSK1654-05-00A	MG SENSOR ASSEMBLY	
94	SSK1649-03-00A	RS232C BOARD ASSEMBLY	
95	SS23023	C-PANEL(L)	
96	SS412476-001	BASE	
97	SS411956	STUD	
98	SSV2459-09	DUSTER COVER	
99	MC71-SCSi	SCSi BOARD ASSEMBLY	
101	SS412305-001	LABEL	
△ 102	WJS0037-001A	E-FL/REWIRE	
103	SS412019-002	PANEL	
104	SS412933	COVER	
105	SS48287-002	LABEL	
106	SS413622-002	C.LABEL(JPN)	
107	SS23020-002	REAR PANEL	
108	SS35948	PCB SUPPORT	
109	SS412861-001	AC LABEL	
110	SC40865-001	LABEL	
111	SS412760	BLIND PANEL(PR)	
112	SS412761	BLIND PANEL(AC)	
113	SSV2458-050	CAP	
114	SS412785	LABEL	
115	SS22476-002	FILTER CASE	
116	SS34931-00A	AIR FILTER	
117	SS22477-002	FILTER CASE	
118	QAR0261-001	FAN MOTOR	
119	SS22737	PLATE	
120	SS412005-001	BRACKET	

Symbol No.	Part No.	Part Name	Description
121	SSK1649-02-00B	CON-FCB ASSEMBLY	
122	SS23019	PCB HOLDER	
123	SSK1649-04-00A	S.MOT ASSEMBLY	
△ 124	QAL0141-001	POWER SUPPLY	
125	QAR0093-001	DC FAN MOTOR	
126	SS11733	COVER	
127	MC71-CHAS	CHASSIS BOARD ASSEMBLY	
128	SS35919	MDP HOLDER	
129	SS412732-A0040	GASKET	
130	QQR0216-001	CLAMP FILTER	
131	SS411880-004	WIRE CLAMP	
132	QNZ0676-001	CN COVER	
133	SCV0465-001	FUSE COVER	
134	SS40341-001	LABEL	
135	SS35086-001	FASTENER	
136	SSV2923	FLAT CORE	
137	HGT19-188UL-NT	GLASS TAPE	
138	SS36057	FAN BRACKET	
139	QAR0261-001	FAN MOTOR	
140	SSV3695	FAN GUIDE	
141	SS411853-F07	SPONGE TAPE	
142	SS411853-F08	SPONGE TAPE	
143	SS412047-001	UL LABEL	
144	SS412174-002	CE/TV LABEL	
145	SS412084-002	FCC LABEL	
146	SS412338-002	LABEL	
147	SS413680-001	C.LABEL(PRN)	
148	SS413572-00A	R.BRACKET ASSEMBLY	
149	SS413578-001	SPRING	
150	SS413575-00A	R.BRACKET (B)ASSEMBLY	
151	SS413571-00A	ROLLER ASSEMBLY	
152	LS30371-001A	PWB BASE	
153	SK250400A1	LVD PWB Ass y	
154	LS40403-001A	CON.PLATE	
S1	SS413571-00A	SCREW	
S2	QYSDST3006M	SCREW	M3 x 6
S3	QYSDSTY3006X	SCREW	M3 x 6
S4	SS411848-001	SCREW	
S5	QYSDSP3005M	SCREW	M3 x 5
S6	QYSBSFG3006M	SCREW	M3 x 6
S7	QYSBSF3008M	SCREW	M3 x 8
S8	QYSDSTY4008N	SCREW	M4 x 8
S9	QYSBSTG3008M	SCREW	M3 x 8
S10	QYSPSPD4008M	SCREW	M4 x 8
S11	QYSDST4008M	SCREW	M3 x 8
S12	QYSPSPD4010Z	SCREW	M4 x 10
S13	SS49420-B3006N	SCREW	M3 x 6
S14	QYSDST4006M	SCREW	M4 x 6
S15	QYSDST3006N	SCREW	M3 x 10
S16	QYSBSFG3008M	SCREW	M3 x 8
S17	QYSDSP3006M	SCREW	M3 x 6
S18	QYSDSF3008M	SCREW	M3 x 8
S19	QYSDSF3006M	SCREW	M3 x 6
S20	QYSDSP3008M	SCREW	M3 x 8
S21	QYSPSPD2604Z	SCREW	M2.6 x 4
S22	QYSSST3008M	SCREW	M3 x 8
S23	QYSPSP3008Z	SCREW	M3 x 8
S24	SS412031-001	SCREW	
S25	QYSPSPL2310Z	SCREW	M2.3 x 10
S26	QYSBSF3012M	SCREW	M3 x 12

Symbol No.	Part No.	Part Name	Description
S27	QYSBSF4035M	SCREW	M4 x 35
S28	QYSBST3006X	SCREW	M3 x 6
S29	QYSDST3006M	SCREW	M3 x 6
S30	QYSBST3025Z	SCREW	M3 x 20
S32	SS412229-002	SCREW	
S33	QYSPSPD4035Z	SCREW	
S34	QYSPSP2604N	SCREW	
S35	LS40316-001A	SCREW	
W1	QYREE2500	RING	
W2	QYWSS439008Z	WASHER	
W4	QYREE3000X	RING	
W5	SS48507-002	WASHER	
W6	QYWFM82C0130	WASHER	

4.3 CARRIER MECHANISM ASSEMBLY M 2

Apply grease (G-31KAV)

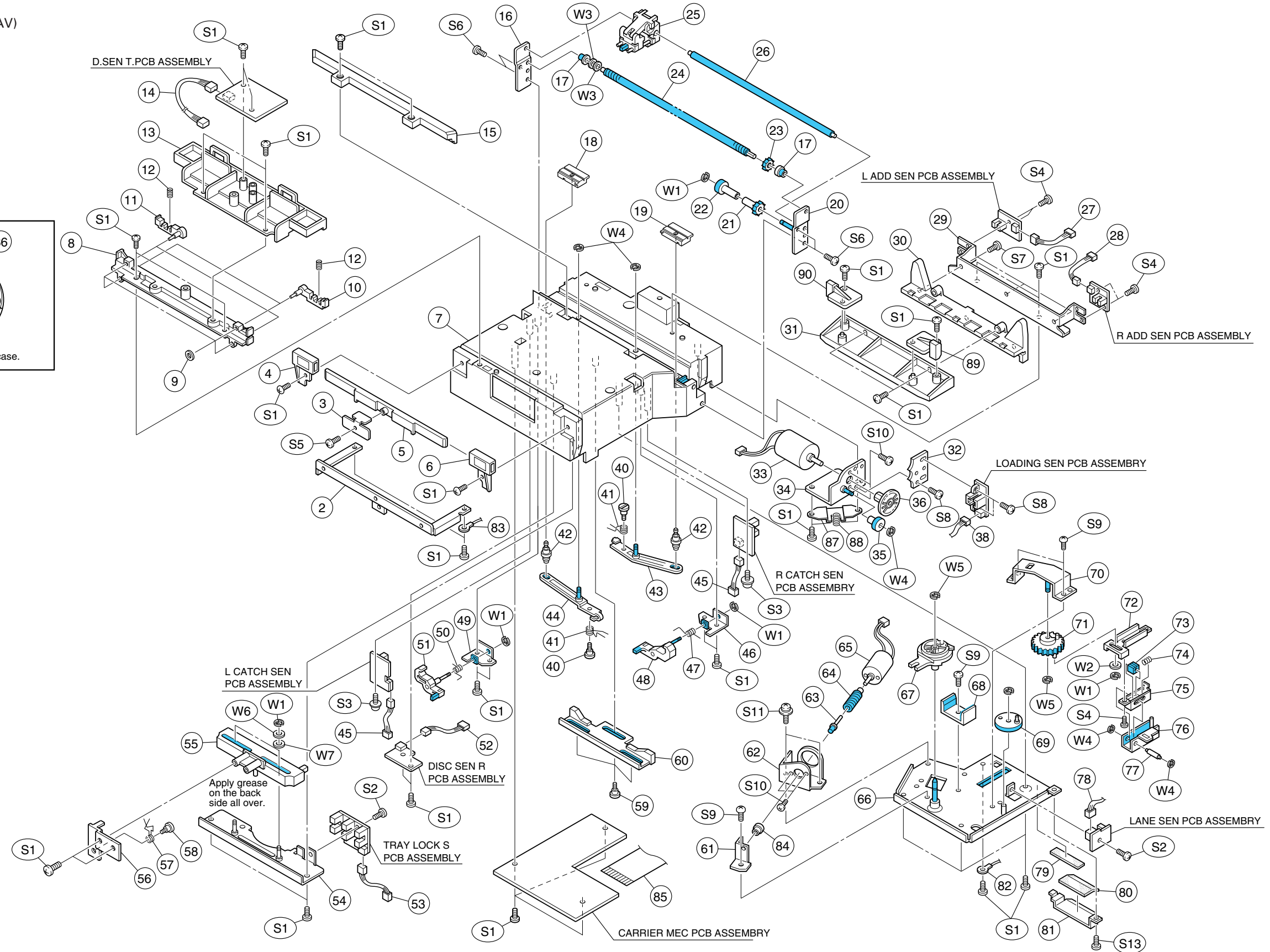
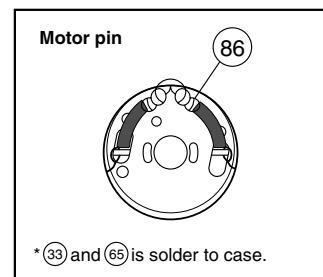

4.4 CARRIER MECHANISM ASSEMBLY PARTS LIST **M 2**

M 2 **M M**

Symbol No.	Part No.	Part Name	Description
2	SS35406-002	ILL.BRACKET	
3	SS412167	TL-BRACKET	
4	SS35343-001	T.L HOLDER	
5	SS411943	T-LINK	
6	SS35343-002	T.L HOLDER	
7	SS22745-00B	C.CHASSIS ASSEMBLY	
8	SS22739	TRAY GUIDE(F)	
9	SS48906-003	STOPPER(1)	
10	SS411807-002	PUSHER	
11	SS411807-001	PUSHER	
12	SS411908-001	SPRING	
13	SS22740	DISK STOPPER(F)	
14	PHY214PH02N	WIRE ASSEMBLY	
15	SS411912	H.RAIL	
16	SS410979-004	S.SUPPORT	
17	SS410982-002	C.H.S.BEARING	
18	SS412600-002	C.SLIDER	
19	SS412600-001	C.SLIDER	
20	SS412737-00A	S.SUPPORT ASSEMBLY	
21	SS48874	J.GEAR	
22	SS411806	J.GEAR	
23	SS410295	C.H.S.GEAR	
24	SS411904	C.H.W.GEAR	
25	SS34908-00D	C. HOLDER ASSEMBLY	
26	SS411903	H.SHAFT	
27	EHT309EH03N	WIRE	
28	EHT312EH03N	WIRE	
29	SS35405	T.G.HOLDER	
30	SS22741	T.GUIDE(R)	
31	SS35344-002	DISK STOPPER(R)	
32	SS410976	S.BASE	
33	SS412733-00A	DC MOTOR	} MC12-LOAD-M (LOADING M ASSY) will be supplied as it can not be disassembled. (W4 and S10 is included)
34	SS411906-00A	TLM BRA ASSEMBLY	
35	SS412735	SL.GEAR	
36	SS412736-00A	SENSOR GEAR ASS'Y	
37	SS23021	WIRE	
38	PHY412PH04N	WIRE	
39	SM3921-001	LABEL	
40	SS410973	LSP.SHAFT	
41	SS410972-002	L.SPRING	
42	SS410966	C.S.SHAFT	
43	SS411915-00A	LEVER(R) ASSEMBLY	
44	SS411902-00A	LEVER(L) ASSEMBLY	
45	PHY307PH03N	WIRE	
46	SS411003-001	CS.BRACKET	
47	SS411002-002	SPRING	
48	SS411907-00B	T.STOPPER ASSEMBLY	
49	SS411003-002	CS.BRACKET	
50	SS411002-001	SPRING	
51	SS411907-00A	T.STOPPER ASSEMBLY	
52	EHT212EH02N	WIRE	
53	PHYD06PH05N	WIRE ASSEMBLY	
54	SS410991-00A	TL.BRACKET ASSEMBLY	
55	SS410993-00A	T.L-LINK ASSEMBLY	
56	SS411911	TLS.BRACKET	
57	SS410997-003	SPRING	
58	SS410996	TL SCREW	
59	SS410999	SCREW	
60	SS35908-00A	CAM BRACKET	

Symbol No.	Part No.	Part Name	Description
61	SS411008-002	BRACKET	} MC12-LOAD-M (LOADING M ASSY) will be supplied as it can not be disassembled. (W4 and S10 is included)
62	SS411009-002	MOTOR BRACKET	
63	SS411007	W.SHAFT	
64	SS411006	WORM GEAR	
65	SSV2793	DC MOTOR	
66	SS412741-00A	BASE ASSEMBLY	
67	SS411025	R.PLATE	
68	SS411010	GUIDE	
69	SS412747-002	PLATE ASSEMBLY	
70	SS412745-00A	BRACKET ASSEMBLY	
71	SS412747-00B	WORM WHEEL ASSEMBLY	
72	SS411017-002	PL BASE	
73	SS411016	SLIDER	
74	SS410961-002	SPRING	
75	SS411015	S.BRACKET	
76	SS412743-003	L.BRACKET ASSEMBLY	
77	SS411021	PIN	
78	EHT408EH04N	WIRE	
79	SS411044-002	CUSHION	
80	SS411044-001	CUSHION	
81	SS411035	WC BRACKET	
82	SS411394-00B	C.WIRE ASSEMBLY	
83	SS411394-00A	C.WIRE ASSEMBLY	
84	SS411340	BUSH	
85	SSV2622-3084B	FLAT CABLE	
86	QCFB1HZ-104YR	C CAP	
87	SS411415	S.BRACKET	
88	SS411419-001	SPRING	
89	SS412141-001	PROTECTOR	
90	SS412141-002	PROTECTOR	
S1	QYSDSF3008M	SCREW	M3 X 8
S2	QYSDSP2604M	SCREW	M2.6 X 4
S3	QYGBSFG3008M	SCREW	M3 X 8
S4	QYSDSP2004M	SCREW	M2 X 4
S5	QYSDSP2008M	SCREW	M2 X 8
S6	QYSDST2005Z	SCREW	M2 X 5
S7	QYSBSF2606Z	SCREW	M2.6 X 6
S8	QYSDSP2006M	SCREW	M2 X 6
S9	QYSDST3006M	SCREW	M3 X 6
S10	QYSPSP3003Z	SCREW	M3 X 3
S11	QYSPSP3006M	SCREW	M3 X 6
S12	QYSDSF2004M	SCREW	M2 X 4
S13	QYSDSP3006M	SCREW	M3 X 6
S14	QYSDST3008M	SCREW	M3 X 8
W1	QYREE2000X	E RING	
W2	QYWSS327005Z	WASHER	
W3	QYWFM264750	POLY WASHER	
W4	REE1500	E RING	
W5	QYREE3000X	E WASHER	
W6	QYWFM315450	POLY WASHER	
W7	QYWFM315425	WASHER	

4.5 MAIL SLOT ASSEMBLY M 3

Apply grease (G-31KAV)

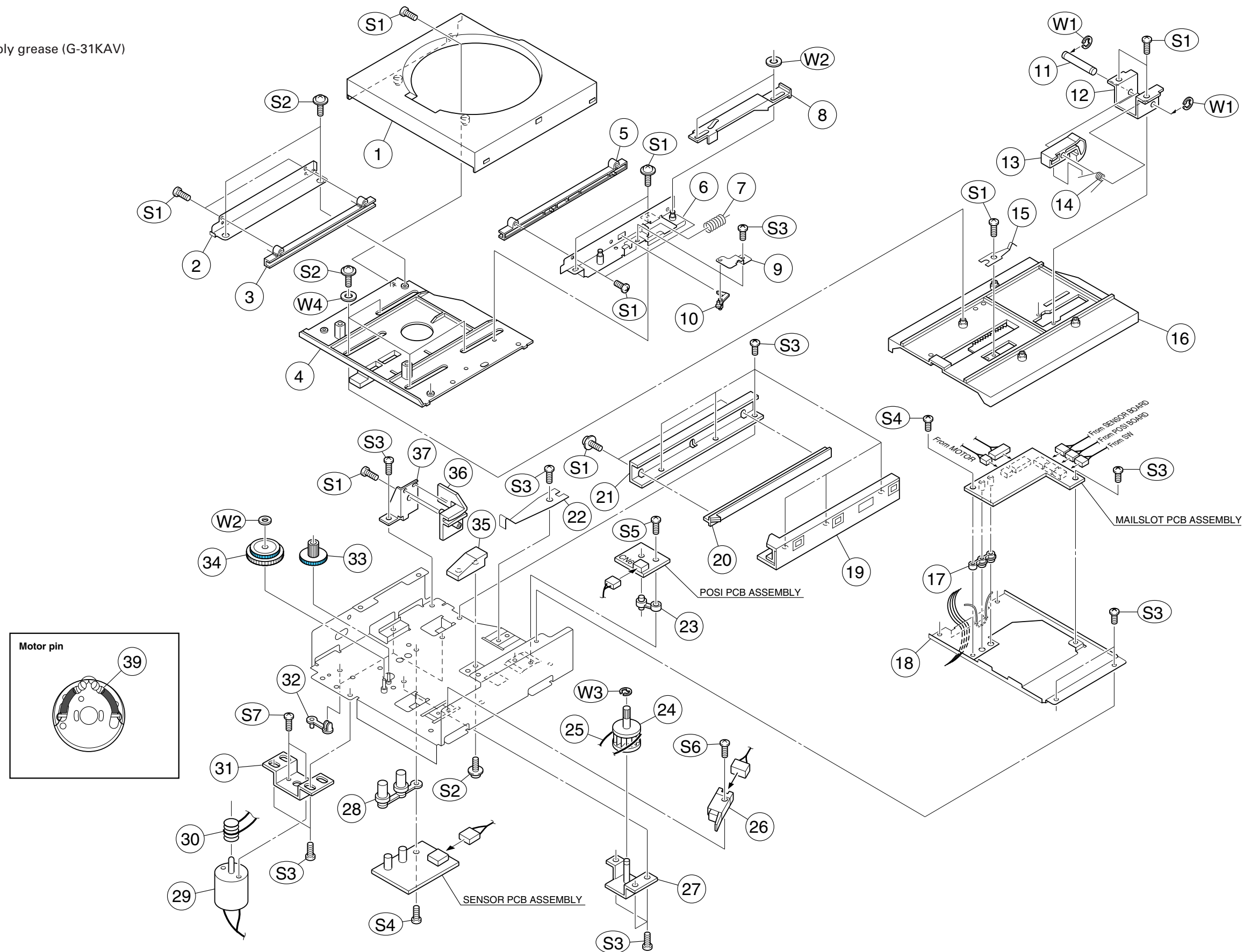

4.6 MAIL SLOT ASSEMBLY PARTS LIST M 3

M 3 M M

Symbol No.	Part No.	Part Name	Description
1	SS11616-002	GUIDE	
2	SS411934	TGR BRACKET	
3	SS35350	TRAY GUIDE(R)	
4	SS22743-002	BASE	
5	SS35349	T.RAIL(F)	
6	SS411927-00B	TGF BKT ASSEMBLY	
7	SS411923-001	SPRING	
8	SS35348	TL PUSHER	
9	SS411938	TLG BRACKET	
10	SS411920	TRAY LOCK	
11	SS411919	SL SHAFT	
12	SS411924-002	ST BRACKET	
13	SS411925-002	STOPPER	
14	SS411922	SPRING	
15	SS411935	P.SPRING(UD)	
16	SS22742	GEAR BASE	
17	SS411929-002	S.GUIDE	
18	SS35409	SEN.HOLDER	
19	SS35347	BASE GUIDE(F)	
20	SS35351	BASE GUIDE(R)	
21	SS411936	BGR BRACKET	
22	SS411942	P.SPRING	
23	SS412048	PCB SPACER	
24	SSV3280	PULLEY-GEAR	
25	SSV3222	BELT	
26	SSV1835	SW	
27	SS411932-00B	P.G.BKT ASSEMBLY	
28	SS411929-001	S.GUIDE	
29	SSV2793	DC MOTOR	} MC12-RAIL-M (RAIL MOTOR ASSY) will be } supplied as it can not be disassembled.
30	SSV3279	PULLEY	
31	SS411930	MOTOR BRACKET	
32	SS411880-003	CLAMP	
33	SS411811	GEAR-3	
34	SS411812	GEAR-4	
35	SS411926	STOPPER(B)	
36	SS35410	TRAY GUIDE(S)	
37	SS411937	TGS BRACKET	
38	SS411941-00B	B.BASE ASSEMBLY	
39	QCFB1HZ-104Y	C CAP	
S1	QYSDSF3006M	SCREW	M3 X 6
S2	QYGBSFG3006M	SCREW	M3 X 6
S3	QYSDST3006M	SCREW	M3 X 8
S4	QYSDST3010M	SCREW	M3 X 10
S5	QYSDSP2610Z	SCREW	M2.6 X 10
S6	QYSDSP2008M	SCREW	M2 X 8
S7	QYSPSP3003Z	SCREW	M3 X 3
W1	QYREE2000	WASHER	
W2	WDL260550-2	WASHER	
W3	QYWDL2140254	WASHER	
W4	QYWFM629513	WASHER	

4.7 MAGAZINE ASSEMBLY M 4

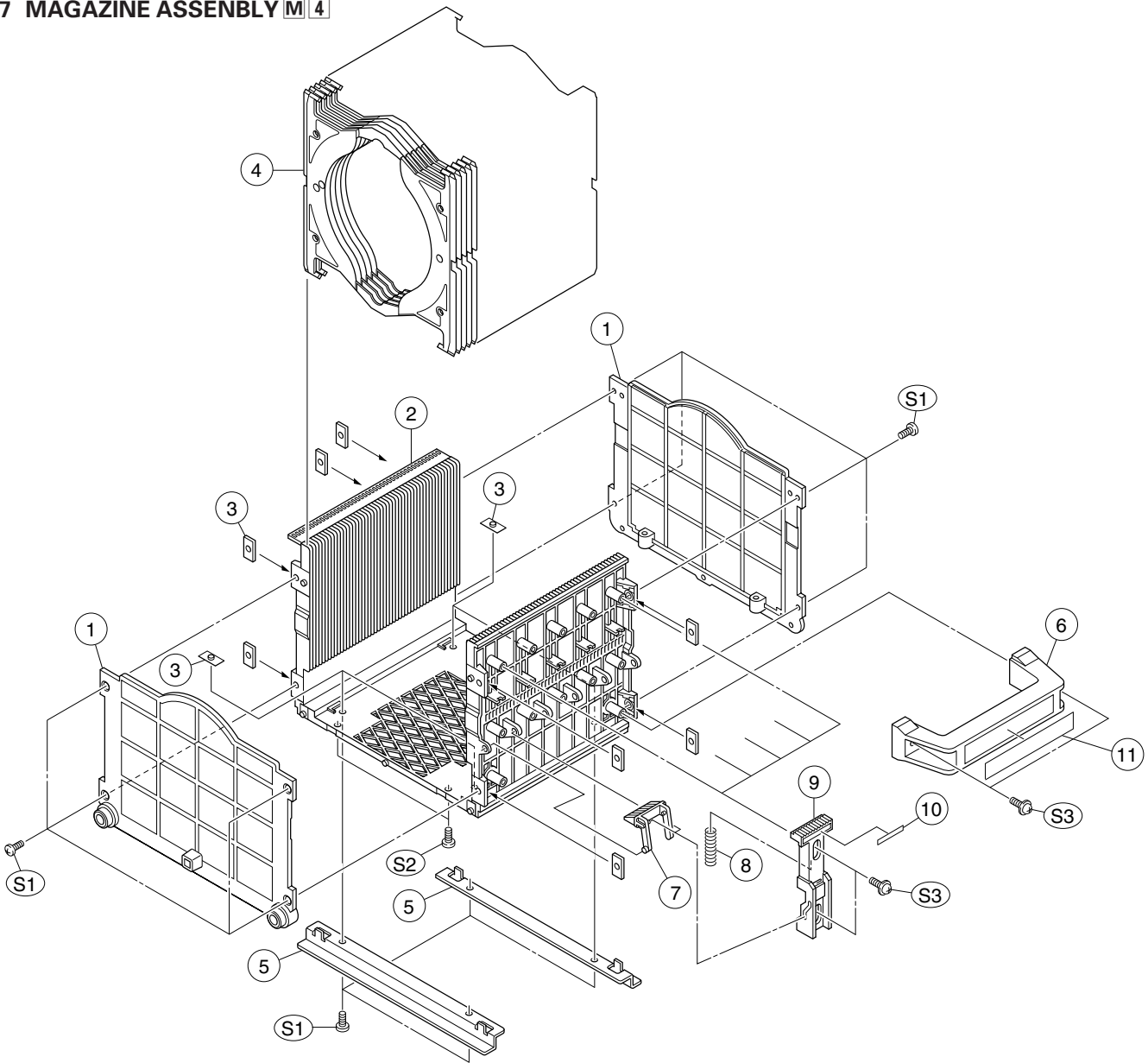

4.8 MAGAZINE ASSEMBLY PARTS LIST M 4

M 4 M M

Symbol No.	Part No.	Part Name	Description
1	SS22736-001	TB PLATE	
2	SS11613-001	RAIL BOX	
3	SS411080-001	NUT PLATE	
4	SS22735-004	TRAY	
5	SS412024-001	R-GUIDE BAR	
6	SS35337-001	GRIP	
7	SS35338-001	TRAY LOCK	
8	SS411084-001	SPRING(TL)	
9	SS35339-001	T.L.PUSHER	
10	SS411851-001	LABEL(ADRS)	(1-50)
11	SS411852-001	LABEL(No. 1-2)	
S1	QYSDSP3008M	SCREW	M3 X 8
S2	QYSBSF3008M	SCREW	M3 X 8
S3	QYGBSFG3008M	SCREW	M3 X 8

4.9 IL BRACKET ASSEMBLY M 5

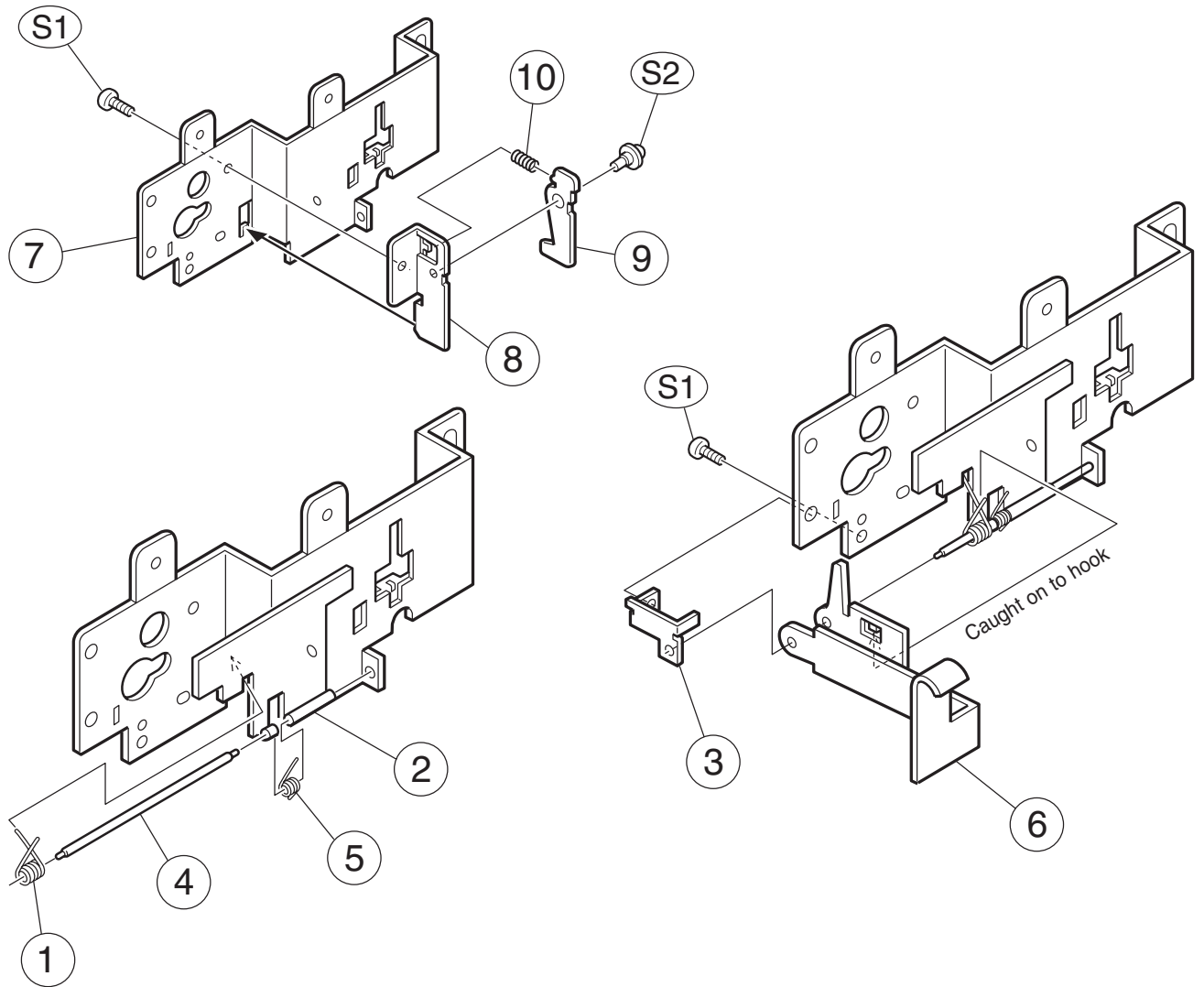

4.10 IL BRACKET ASSEMBLY PARTS LIST M 5

M 5 M M □ □ □ □

Symbol No.	Part No.	Part Name	Description
1	SS412119	SPRING(SDL-A)	
2	SS412762	SDL-HOOK	
3	SS412763	SDL-SHAFT BRACKET	
4	SS412118-001	SDL-SHAFT	
5	SS412120	SPRING(SDL-B)	
6	SS35500-002	SDL-LEVER	
7	SS35949-002	IL BRACKET	
8	SS412475-003	CPLH BASE	
9	SS412474-003	CPL-HOOK	
10	SS412481-002	SPRING	
S1	QYSDST3006M	SCREW	
S2	SS411339-001	SCREW	

4.11 U/D MECHANISM ASSEMBLY M 6

MOTOR UNIT

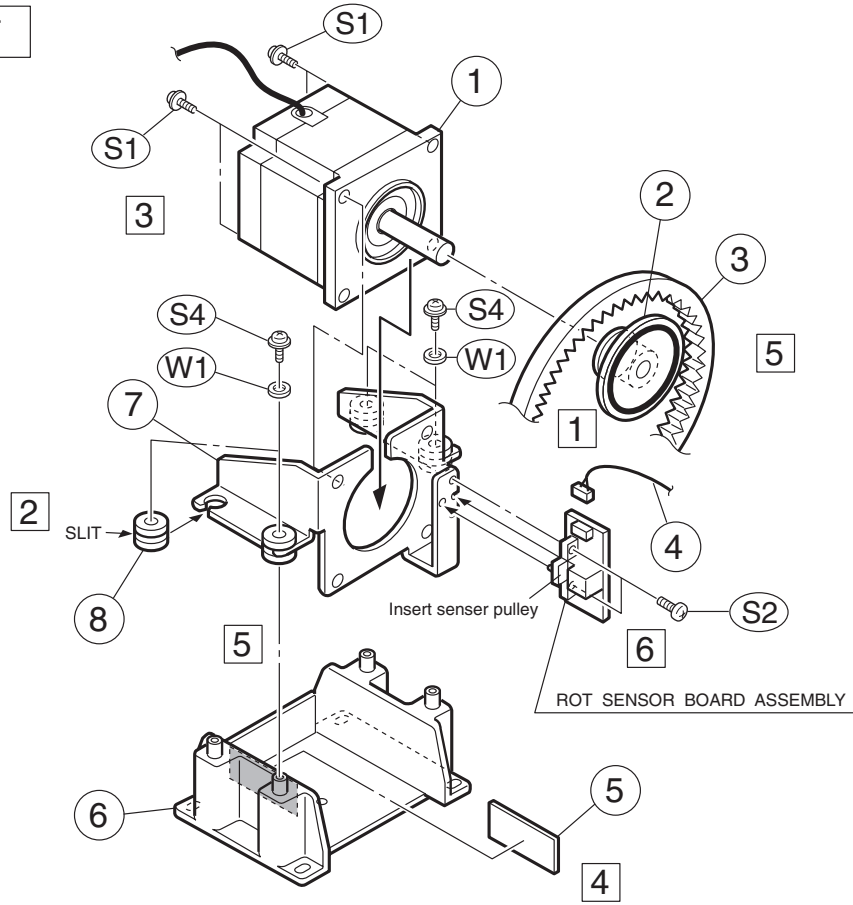

PULLEY UNIT

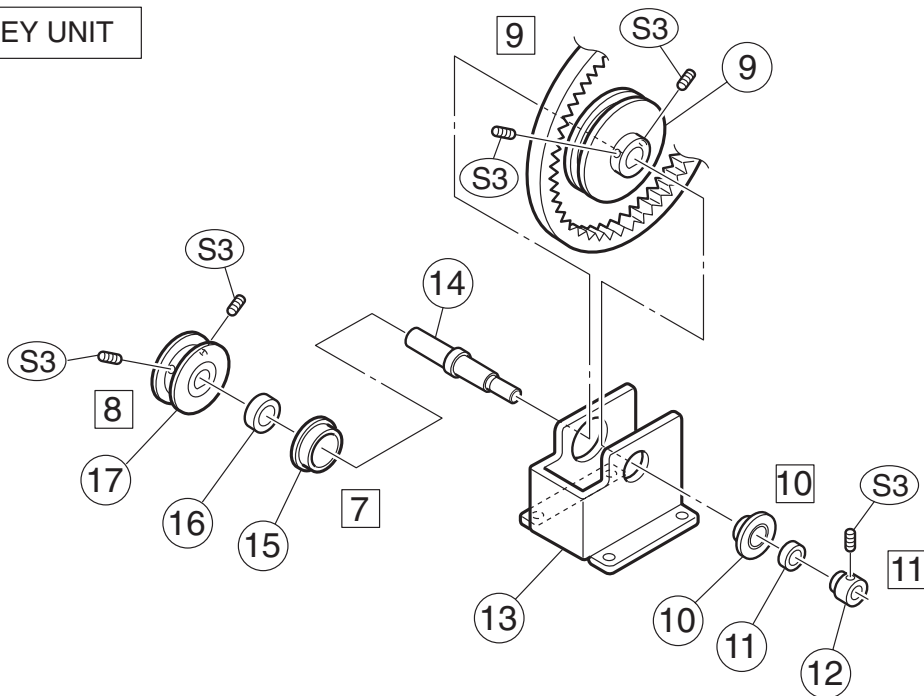

4.12 U/D MECHANISM ASSEMBLY PARTS LIST M 6

M 6 M M

Symbol No.	Part No.	Part Name	Description
1	QAR0089-001	MOTOR	
2	SS412777-00B	SENSOR PULLEY	
3	QZW0026-001	BELT	
4	SS412772-0RS	C.WIRE	
5	SS412897-001	CUSHION	
6	SS35936-00A	MOTOR BASE ASSEMBLY	
7	SS35934-001	MOTOR BRACKET	
8	SS412802-001	DAMPER	
9	SS412778-00B	PULLEY	
10	SS412779-001	B.HOLDER(105)	
11	SS410822-001	BEARING(688ZZ)	
12	SS412780-001	STOPPER	
13	SS35935-001	P.BRACKET	
14	SS412781-001	P.SHAFT	
15	SS410813	B.HOLDER	
16	SS45160-006	B.BEARING(MR105)	
17	SS49074-00B	PULLEY(T)ASSEMBLY	
S1	QYSPSPL4010Z	SCREW	
S2	QYSDSP2604M	SCREW	
S3	QYYASPR3006M	SCREW	
S4	QYSPSPL3008M	SCREW	
W1	QYWWS32B008Z	WASHER	

SECTION 5

ELECTRICAL PARTS LIST

SAFETY PRECAUTION:

Parts identified by the \triangle symbol are critical for safety. Replace only with specified parts numbers.
For maximum reliability and performance, all other replacement parts should be identical to those specified.

NOTE:

- Parts not denoted by parts numbers are not supplied by JVC.
- Abbreviations in this list are as follows:

RESISTORS

In the Description column:

- All resistance values are in ohms (Ω).
- k expresses kilo-ohm (1 000 ohms, $k\Omega$).
- M expresses mega-ohm (10^6 ohms, $M\Omega$).

In the Parts Name column:

- CAR.RESISTOR : Carbon Resistor
- C.M.F.RESISTOR : Constant Metalized Film Resistor
- COMP.RESISTOR: Composition Resistor
- FUSI.RESISTOR : Fusible Resistor
- M.F.RESISTOR : Metal Film Resistor
- M.G.RESISTOR : Metal Graze Resistor
- M.P.RESISTOR : Metal Plate Resistor
- O.M.F.RESISTOR : Oxide Metalized Film Resistor
- TRIM.RESISTOR : Trimerer Resistor
- U.F.RESISTOR : Non-inflammable Resistor
- VAL.RESISTOR : Valiable Resistor
- W.W.RESISTOR : Wire Wound Resistor

CAPACITORS

In the Description column:

- All capacitance values are in microfarad (μF) unless otherwise indicated.
- p expresses picofarad (10^{-12} farad,pF).

In the Parts Name column:

- CER.CAPACITOR : Ceramic Capacitor
- E.CAPACITOR : Electrolytic Capacitor
- FILM CAPACITOR : Film Capacitor
- M.F.CAPACITOR : Metalized Film Capacitor
- MICA CAPACITOR : Mica Capacitor
- MPP CAPACITOR : Metalized PolyPropylene Capacitor
- MPPS CAPACITOR : Metalized PolyPhenylene Sulfied film Capacitor
- M.M.CAPACITOR : Metalized Mylar Capacitor
- MYLAR CAPACITOR : Mylar Capacitor
- N.P.CAPACITOR : Non-Poler electrolytic Capacitor
- P.P.CAPACITOR : PolyPropylene Capacitor
- PPS CAPACITOR : PolyPhenylene Sulfied film Capacitor
- P.S.CAPACITOR : PolyStyrene Capacitor
- TAN.CAPACITOR : Tantal Capacitor
- TRIM.CAPACITOR : Trimer Capacitor
- VAL.CAPACITOR : Valiable Capacitor

5.1 CHASSIS BOARD ASSEMBLY PARTS LIST 0 1

0 1 □ □ □ □ □ □ □ □

Symbol No.	Part No.	Part Name	Description
IC1	HB90T678BPF	I.C.	
IC2	MC74AC573N	I.C.	
IC3	MC74AC573N	I.C.	
IC4	PLSS1610	EP-ROM	M27C1024-10F1
IC5	HA16103FPS	I.C.	
IC6	MC74HC04AN	I.C.(DIGI-MOS)	MOTOROLA
IC7	MC74HC08AN	I.C.(M)	MOTOROLA
IC8	SN74HC138N	I.C.(DIGI-MOS)	TEXAS
IC9	SN74HC138N	I.C.(DIGI-MOS)	TEXAS
IC10	SN74HC174N	I.C.(M)	
IC11	SN74HC174N	I.C.(M)	
IC12	SN74HC174N	I.C.(M)	
IC14	BA6259N	I.C.(MONO-ANA)	
IC15	BA6259N	I.C.(MONO-ANA)	
IC18	SN74HC245N	I.C.(DIGI-MOS)	TEXAS
IC19	SN74HC245N	I.C.(DIGI-MOS)	TEXAS
IC20	SN74HC245N	I.C.(DIGI-MOS)	TEXAS
IC21	SN74HC245N	I.C.(DIGI-MOS)	TEXAS
IC22	SN74HC245N	I.C.(DIGI-MOS)	TEXAS
IC23	BA6239A	I.C.	
IC24	MP4006	POW TRANSISTOR	
IC25	MC74HC04AN	I.C.(DIGI-MOS)	MOTOROLA
Q1	2SC3311A/RS-T	SI.TRANSISTOR	MATSUSHITA
Q2	2SC3311A/RS-T	SI.TRANSISTOR	MATSUSHITA
Q3	2SC3311A/RS-T	SI.TRANSISTOR	MATSUSHITA
D1	ERA82-004-T1	SI.DIODE	
D2	HZ3B2	ZENER DIODE	HITACHI
D3	MA700A-T2	DIODE	MATSUSHITA
D4	ERA82-004-T1	SI.DIODE	
D5	ERA82-004-T1	SI.DIODE	
D6	ERA82-004-T1	SI.DIODE	
D7	ERA82-004-T1	SI.DIODE	
D8	ERA15-02-T1	DIODE	FIJI ELECTRIC
D9	ERA15-02-T1	DIODE	FIJI ELECTRIC
D10	ERA15-02-T1	DIODE	FIJI ELECTRIC
LD1	SEL6410G-T	L.E.D.	
LD2	SEL6410G-T	L.E.D.	
LD3	SEL6410G-T	L.E.D.	
R1	QRE141J-152Y	CARBON RESISTOR	1.5K 1/4W
R2	QRE141J-152Y	CARBON RESISTOR	1.5K 1/4W
R3	QRE141J-471Y	CARBON RESISTOR	470 1/4W
R4	QRE141J-472Y	CARBON RESISTOR	4.7K 1/4W
R5	QRE141J-472Y	CARBON RESISTOR	4.7K 1/4W
R6	QRE141J-103Y	CARBON RESISTOR	10K 1/4W
R7	QRE141J-391Y	CARBON RESISTOR	391 1/4W
R8	QRE141J-101Y	CARBON RESISTOR	100 1/4W
R9	QRE141J-474Y	CARBON RESISTOR	470K 1/4W
R10	QRE141J-474Y	CARBON RESISTOR	470K 1/4W
R11	QRE141J-103Y	CARBON RESISTOR	10K 1/4W
R12	QRE141J-273Y	CARBON RESISTOR	27K 1/4W
R13	QRE141J-103Y	CARBON RESISTOR	10K 1/4W
R14	QRE141J-472Y	CARBON RESISTOR	4.7K 1/4W
R16	QRE141J-2R2Y	CR	2.2 1/4W
R17	QRE141J-2R2Y	CR	2.2 1/4W
R48	QRE141J-472Y	CARBON RESISTOR	4.7K 1/4W
R49	QRE141J-472Y	CARBON RESISTOR	4.7K 1/4W
R50	QRE141J-472Y	CARBON RESISTOR	4.7K 1/4W
R51	QRE141J-472Y	CARBON RESISTOR	4.7K 1/4W
R52	QRE141J-472Y	CARBON RESISTOR	4.7K 1/4W
R53	QRE141J-472Y	CARBON RESISTOR	4.7K 1/4W
R54	QRE141J-472Y	CARBON RESISTOR	4.7K 1/4W
R55	QRE141J-101Y	CARBON RESISTOR	100 1/4W
R56	QRE141J-101Y	CARBON RESISTOR	100 1/4W
R57	QRE141J-101Y	CARBON RESISTOR	100 1/4W
R58	QRE141J-101Y	CARBON RESISTOR	100 1/4W
R59	QRE141J-101Y	CARBON RESISTOR	100 1/4W
R60	QRE141J-101Y	CARBON RESISTOR	100 1/4W
R61	QRE141J-101Y	CARBON RESISTOR	100 1/4W

Symbol No.	Part No.	Part Name	Description
R62	QRE141J-101Y	CARBON RESISTOR	100 1/4W
R63	QRE141J-472Y	CARBON RESISTOR	4.7K 1/4W
R64	QRE141J-472Y	CARBON RESISTOR	4.7K 1/4W
R65	QRE141J-472Y	CARBON RESISTOR	4.7K 1/4W
R66	QRE141J-472Y	CARBON RESISTOR	4.7K 1/4W
R67	QRE141J-472Y	CARBON RESISTOR	4.7K 1/4W
R68	QRE141J-472Y	CARBON RESISTOR	4.7K 1/4W
R69	QRE141J-472Y	CARBON RESISTOR	4.7K 1/4W
R70	QRE141J-101Y	CARBON RESISTOR	100 1/4W
R71	QRE141J-101Y	CARBON RESISTOR	100 1/4W
R72	QRE141J-101Y	CARBON RESISTOR	100 1/4W
R73	QRE141J-101Y	CARBON RESISTOR	100 1/4W
R74	QRE141J-101Y	CARBON RESISTOR	100 1/4W
R75	QRE141J-101Y	CARBON RESISTOR	100 1/4W
R76	QRE141J-101Y	CARBON RESISTOR	100 1/4W
R77	QRE141J-101Y	CARBON RESISTOR	100 1/4W
R78	QRE141J-472Y	CARBON RESISTOR	4.7K 1/4W
R79	QRE141J-472Y	CARBON RESISTOR	4.7K 1/4W
R80	QRE141J-472Y	CARBON RESISTOR	4.7K 1/4W
R81	QRE141J-472Y	CARBON RESISTOR	4.7K 1/4W
R82	QRE141J-472Y	CARBON RESISTOR	4.7K 1/4W
R83	QRE141J-472Y	CARBON RESISTOR	4.7K 1/4W
R84	QRE141J-472Y	CARBON RESISTOR	4.7K 1/4W
R85	QRE141J-101Y	CARBON RESISTOR	100 1/4W
R86	QRE141J-101Y	CARBON RESISTOR	100 1/4W
R87	QRE141J-101Y	CARBON RESISTOR	100 1/4W
R88	QRE141J-101Y	CARBON RESISTOR	100 1/4W
R89	QRE141J-101Y	CARBON RESISTOR	100 1/4W
R90	QRE141J-101Y	CARBON RESISTOR	100 1/4W
R91	QRE141J-101Y	CARBON RESISTOR	100 1/4W
R92	QRE141J-101Y	CARBON RESISTOR	100 1/4W
R93	QRE141J-472Y	CARBON RESISTOR	4.7K 1/4W
R94	QRE141J-472Y	CARBON RESISTOR	4.7K 1/4W
R95	QRE141J-472Y	CARBON RESISTOR	4.7K 1/4W
R96	QRE141J-472Y	CARBON RESISTOR	4.7K 1/4W
R97	QRE141J-472Y	CARBON RESISTOR	4.7K 1/4W
R98	QRE141J-472Y	CARBON RESISTOR	4.7K 1/4W
R99	QRE141J-472Y	CARBON RESISTOR	4.7K 1/4W
R100	QRE141J-101Y	CARBON RESISTOR	100 1/4W
R101	QRE141J-101Y	CARBON RESISTOR	100 1/4W
R102	QRE141J-101Y	CARBON RESISTOR	100 1/4W
R103	QRE141J-101Y	CARBON RESISTOR	100 1/4W
R104	QRE141J-101Y	CARBON RESISTOR	100 1/4W
R105	QRE141J-101Y	CARBON RESISTOR	100 1/4W
R106	QRE141J-101Y	CARBON RESISTOR	100 1/4W
R107	QRE141J-101Y	CARBON RESISTOR	100 1/4W
R108	QRE141J-101Y	CARBON RESISTOR	100 1/4W
R109	QRE141J-101Y	CARBON RESISTOR	100 1/4W
R110	QRE141J-101Y	CARBON RESISTOR	100 1/4W
R111	QRE141J-103Y	CARBON RESISTOR	10K 1/4W
R112	QRE141J-103Y	CARBON RESISTOR	10K 1/4W
R113	QRE141J-101Y	CARBON RESISTOR	100 1/4W
R114	QRE141J-101Y	CARBON RESISTOR	100 1/4W
R115	QRE141J-101Y	CARBON RESISTOR	100 1/4W
R116	QRE141J-101Y	CARBON RESISTOR	100 1/4W
R117	QRE141J-101Y	CARBON RESISTOR	100 1/4W
R118	QRE141J-101Y	CARBON RESISTOR	100 1/4W
R119	QRE141J-101Y	CARBON RESISTOR	100 1/4W
R120	QRE141J-101Y	CARBON RESISTOR	100 1/4W
R121	QRE141J-101Y	CARBON RESISTOR	100 1/4W
R122	QRE141J-101Y	CARBON RESISTOR	100 1/4W
R123	QRE141J-101Y	CARBON RESISTOR	100 1/4W
R124	QRE141J-101Y	CARBON RESISTOR	100 1/4W
R125	QRE141J-101Y	CARBON RESISTOR	100 1/4W
R126	QRE141J-101Y	CARBON RESISTOR	100 1/4W
R127	QRE141J-472Y	CARBON RESISTOR	4.7K 1/4W
R128	QRE141J-472Y	CARBON RESISTOR	4.7K 1/4W
R129	QRE141J-101Y	CARBON RESISTOR	100 1/4W
R130	QRE141J-101Y	CARBON RESISTOR	100 1/4W
R131	QRE141J-101Y	CARBON RESISTOR	100 1/4W
R132	QRE141J-101Y	CARBON RESISTOR	100 1/4W
R133	QRE141J-101Y	CARBON RESISTOR	100 1/4W

[CHASSIS]

Symbol No.	Part No.	Part Name	Description
R134	QRE141J-101Y	CARBON RESISTOR	100 1/4W
R135	QRE141J-472Y	CARBON RESISTOR	4.7K 1/4W
R136	QRE141J-101Y	CARBON RESISTOR	100 1/4W
R137	QRE141J-101Y	CARBON RESISTOR	100 1/4W
R138	QRE141J-101Y	CARBON RESISTOR	100 1/4W
R139	QRE141J-101Y	CARBON RESISTOR	100 1/4W
R140	QRE141J-472Y	CARBON RESISTOR	4.7K 1/4W
R141	QRE141J-472Y	CARBON RESISTOR	4.7K 1/4W
R142	QRE141J-472Y	CARBON RESISTOR	4.7K 1/4W
R143	QRE141J-472Y	CARBON RESISTOR	4.7K 1/4W
R145	QRE141J-472Y	CARBON RESISTOR	4.7K 1/4W
R146	QRE141J-472Y	CARBON RESISTOR	4.7K 1/4W
R147	QRE141J-472Y	CARBON RESISTOR	4.7K 1/4W
R148	QRE141J-472Y	CARBON RESISTOR	4.7K 1/4W
R149	QRE141J-472Y	CARBON RESISTOR	4.7K 1/4W
R150	QRE141J-472Y	CARBON RESISTOR	4.7K 1/4W
R151	QRE141J-472Y	CARBON RESISTOR	4.7K 1/4W
R152	QRE141J-472Y	CARBON RESISTOR	4.7K 1/4W
R153	QRE141J-472Y	CARBON RESISTOR	4.7K 1/4W
R154	QRE141J-472Y	CARBON RESISTOR	4.7K 1/4W
R155	QRE141J-472Y	CARBON RESISTOR	4.7K 1/4W
R156	QRE141J-101Y	CARBON RESISTOR	100 1/4W
R157	QRE141J-101Y	CARBON RESISTOR	100 1/4W
R158	QRE141J-101Y	CARBON RESISTOR	100 1/4W
R159	QRE141J-101Y	CARBON RESISTOR	100 1/4W
R160	QRE141J-101Y	CARBON RESISTOR	100 1/4W
R161	QRE141J-101Y	CARBON RESISTOR	100 1/4W
R162	QRE141J-101Y	CARBON RESISTOR	100 1/4W
R164	QRE141J-101Y	CARBON RESISTOR	100 1/4W
R165	QRE141J-101Y	CARBON RESISTOR	100 1/4W
R166	QRE141J-101Y	CARBON RESISTOR	100 1/4W
R167	QRE141J-101Y	CARBON RESISTOR	100 1/4W
R168	QRE141J-101Y	CARBON RESISTOR	100 1/4W
R169	QRE141J-472Y	CARBON RESISTOR	4.7K 1/4W
R170	QRE141J-472Y	CARBON RESISTOR	4.7K 1/4W
R171	QRE141J-101Y	CARBON RESISTOR	100 1/4W
R172	QRE141J-101Y	CARBON RESISTOR	100 1/4W
R173	QRE141J-471Y	CARBON RESISTOR	470 1/4W
R174	QRE141J-101Y	CARBON RESISTOR	100 1/4W
R177	QRE141J-103Y	CARBON RESISTOR	10K 1/4W
R178	QRE141J-103Y	CARBON RESISTOR	10K 1/4W
R179	QRE141J-152Y	CARBON RESISTOR	1.5K 1/4W
R180	QRE141J-152Y	CARBON RESISTOR	1.5K 1/4W
R181	QRE141J-152Y	CARBON RESISTOR	1.5K 1/4W
R182	QRE141J-152Y	CARBON RESISTOR	1.5K 1/4W
R183	QRE141J-271Y	CARBON RESISTOR	270 1/4W
R184	QRE141J-271Y	CARBON RESISTOR	270 1/4W
R185	QRE141J-152Y	CARBON RESISTOR	1.5K 1/4W
R186	QRE141J-271Y	CARBON RESISTOR	270 1/4W
R187	QRE141J-271Y	CARBON RESISTOR	270 1/4W
R188	QRE141J-152Y	CARBON RESISTOR	1.5K 1/4W
R190	QRE141J-472Y	CARBON RESISTOR	4.7K 1/4W
R191	QRE141J-101Y	CARBON RESISTOR	100 1/4W
R192	QRE141J-103Y	CARBON RESISTOR	10K 1/4W
R193	QRE141J-103Y	CARBON RESISTOR	10K 1/4W
R194	QRE141J-103Y	CARBON RESISTOR	10K 1/4W
R195	QRE141J-103Y	CARBON RESISTOR	10K 1/4W
R196	QRE141J-472Y	CARBON RESISTOR	4.7K 1/4W
R197	QRE141J-472Y	CARBON RESISTOR	4.7K 1/4W
R198	QRE141J-472Y	CARBON RESISTOR	4.7K 1/4W
R199	QRE141J-472Y	CARBON RESISTOR	4.7K 1/4W
R200	QRE141J-472Y	CARBON RESISTOR	4.7K 1/4W
R201	QRE141J-472Y	CARBON RESISTOR	4.7K 1/4W
R202	QRE141J-472Y	CARBON RESISTOR	4.7K 1/4W
R203	QRE141J-103Y	CARBON RESISTOR	10K 1/4W
R204	QRE141J-103Y	CARBON RESISTOR	10K 1/4W
R205	QRE141J-103Y	CARBON RESISTOR	10K 1/4W
R206	QRE141J-470Y	CAROBN RESISTOR	47 1/4W
R207	QRE141J-470Y	CAROBN RESISTOR	47 1/4W
R210	QRE141J-224Y	CAROBN RESISTOR	220K
C1	QETC1CM-476Z	AL.E.CAPACITOR	47 16V

Symbol No.	Part No.	Part Name	Description
C2	QETC1CM-227Z	E.CAPACITOR	220 16V
C4	QCZ0206-104Z	CER.CAPACITOR-S	0.10
C5	QETC1CM-227Z	E.CAPACITOR	220 16V
C6	QCZ0206-104Z	CER.CAPACITOR-S	0.10
C7	QETC1CM-476Z	AL.E.CAPACITOR	47 16V
C8	QCZ0206-104Z	CER.CAPACITOR-S	0.10
C9	QCZ0206-104Z	CER.CAPACITOR-S	0.10
C10	QETC1CM-476Z	AL.E.CAPACITOR	47 16V
C11	QCZ0206-104Z	CER.CAPACITOR-S	0.10
C12	QETC1CM-476Z	AL.E.CAPACITOR	47 16V
C13	QCZ0206-104Z	CER.CAPACITOR-S	0.10
C14	QCZ0206-104Z	CER.CAPACITOR-S	0.10
C15	QCZ0206-104Z	CER.CAPACITOR-S	0.10
C16	QDC31HJ-101Z	C CAP	
C17	QDC31HJ-101Z	C CAP	
C18	QCZ0206-104Z	CER.CAPACITOR-S	0.10
C19	QCZ0206-104Z	CER.CAPACITOR-S	0.10
C20	QCZ0206-104Z	CER.CAPACITOR-S	0.10
C21	QCZ0206-104Z	CER.CAPACITOR-S	0.10
C22	QCFB1HZ-104Y	C CAP	0.10 50V
C23	QCZ0206-104Z	CER.CAPACITOR-S	0.10
C24	QETC1CM-476Z	AL.E.CAPACITOR	47 16V
C25	QCZ0206-104Z	CER.CAPACITOR-S	0.10
C26	QCZ0206-104Z	CER.CAPACITOR-S	0.10
C27	QFN31HJ-473Z	MY CAP	0.047 50V
C28	QFN31HJ-103Z	MY.CAPACITOR/CV	0.010 50V
C29	QCB1HK-102Y	CER.CAPACITOR-S	1000P 50V
C30	QFN31HJ-103Z	MY.CAPACITOR/CV	0.010 50V
C31	QFN31HJ-103Z	MY.CAPACITOR/CV	0.010 50V
C32	QCB1HK-102Y	CER.CAPACITOR-S	1000P 50V
C33	QCB1HK-102Y	CER.CAPACITOR-S	1000P 50V
C34	QCZ0206-104Z	CER.CAPACITOR-S	0.10
C35	QCZ0206-104Z	CER.CAPACITOR-S	0.10
C36	QCZ0206-104Z	CER.CAPACITOR-S	0.10
C37	QCZ0206-104Z	CER.CAPACITOR-S	0.10
C38	QCZ0206-104Z	CER.CAPACITOR-S	0.10
C39	QCZ0206-104Z	CER.CAPACITOR-S	0.10
C40	QCZ0206-104Z	CER.CAPACITOR-S	0.10
C42	QETC1CM-476Z	AL.E.CAPACITOR	47 16V
C43	QETC1CM-476Z	AL.E.CAPACITOR	47 16V
C60	QCZ0206-104Z	CER.CAPACITOR-S	0.10
C61	QCB1HK-102Y	CER.CAPACITOR-S	1000P 50V
C62	QCB1HK-102Y	CER.CAPACITOR-S	1000P 50V
C63	QCB1HK-102Y	CER.CAPACITOR-S	1000P 50V
C64	QCB1HK-102Y	CER.CAPACITOR-S	1000P 50V
C65	QCB1HK-102Y	CER.CAPACITOR-S	1000P 50V
C66	QCB1HK-102Y	CER.CAPACITOR-S	1000P 50V
C67	QCB1HK-102Y	CER.CAPACITOR-S	1000P 50V
C68	QCZ0206-104Z	CER.CAPACITOR-S	0.10
C69	QCB1HK-102Y	CER.CAPACITOR-S	1000P 50V
C70	QCB1HK-102Y	CER.CAPACITOR-S	1000P 50V
C71	QCB1HK-102Y	CER.CAPACITOR-S	1000P 50V
C72	QCB1HK-102Y	CER.CAPACITOR-S	1000P 50V
C73	QCB1HK-102Y	CER.CAPACITOR-S	1000P 50V
C74	QCB1HK-102Y	CER.CAPACITOR-S	1000P 50V
C75	QCB1HK-102Y	CER.CAPACITOR-S	1000P 50V
C76	QCZ0206-104Z	CER.CAPACITOR-S	0.10
C77	QCB1HK-102Y	CER.CAPACITOR-S	1000P 50V
C78	QCB1HK-102Y	CER.CAPACITOR-S	1000P 50V
C79	QCB1HK-102Y	CER.CAPACITOR-S	1000P 50V
C80	QCB1HK-102Y	CER.CAPACITOR-S	1000P 50V
C81	QCB1HK-102Y	CER.CAPACITOR-S	1000P 50V
C82	QCB1HK-102Y	CER.CAPACITOR-S	1000P 50V
C83	QCB1HK-102Y	CER.CAPACITOR-S	1000P 50V
C84	QCZ0206-104Z	CER.CAPACITOR-S	0.10
C85	QCB1HK-102Y	CER.CAPACITOR-S	1000P 50V
C86	QCB1HK-102Y	CER.CAPACITOR-S	1000P 50V
C87	QCB1HK-102Y	CER.CAPACITOR-S	1000P 50V
C88	QCB1HK-102Y	CER.CAPACITOR-S	1000P 50V
C89	QCB1HK-102Y	CER.CAPACITOR-S	1000P 50V
C90	QCB1HK-102Y	CER.CAPACITOR-S	1000P 50V
C91	QCB1HK-102Y	CER.CAPACITOR-S	1000P 50V
C96	QCZ0206-104Z	CER.CAPACITOR-S	0.10

Symbol No.	Part No.	Part Name	Description
C97	QCZ0206-104Z	CER.CAPACITOR-S	0.10
C98	QCZ0206-104Z	CER.CAPACITOR-S	0.10
C99	QCZ0206-104Z	CER.CAPACITOR-S	0.10
C100	QCZ0206-104Z	CER.CAPACITOR-S	0.10
C101	QCZ0206-104Z	CER.CAPACITOR-S	0.10
C102	QCZ0206-104Z	CER.CAPACITOR-S	0.10
C103	QCZ0206-104Z	CER.CAPACITOR-S	0.10
C104	QCZ0206-104Z	CER.CAPACITOR-S	0.10
C105	QCZ0206-104Z	CER.CAPACITOR-S	0.10
C106	QCZ0206-104Z	CER.CAPACITOR-S	0.10
C107	QCB1HK-102Y	CER.CAPACITOR-S	1000P 50V
C108	QCB1HK-102Y	CER.CAPACITOR-S	1000P 50V
C109	QCZ0206-104Z	CER.CAPACITOR-S	0.10
C110	QCB1HK-102Y	CER.CAPACITOR-S	1000P 50V
C111	QCZ0206-104Z	CER.CAPACITOR-S	0.10
C112	QCZ0206-104Z	CER.CAPACITOR-S	0.10
C113	QCZ0206-104Z	CER.CAPACITOR-S	0.10
C114	QCB1HK-102Y	CER.CAPACITOR-S	1000P 50V
C115	QCB1HK-102Y	CER.CAPACITOR-S	1000P 50V
C116	QCB1HK-102Y	CER.CAPACITOR-S	1000P 50V
C117	QCB1HK-102Y	CER.CAPACITOR-S	1000P 50V
C118	QETC1CM-476Z	AL.E.CAPACITOR	47 16V
C119	QCZ0206-104Z	CER.CAPACITOR-S	0.10
C120	QCB1HK-102Y	CER.CAPACITOR-S	1000P 50V
C121	QCB1HK-102Y	CER.CAPACITOR-S	1000P 50V
C122	QCB1HK-102Y	CER.CAPACITOR-S	1000P 50V
C123	QCB1HK-102Y	CER.CAPACITOR-S	1000P 50V
C124	QCB1HK-102Y	CER.CAPACITOR-S	1000P 50V
C125	QCB1HK-102Y	CER.CAPACITOR-S	1000P 50V
C126	QCB1HK-102Y	CER.CAPACITOR-S	1000P 50V
C127	QCB1HK-102Y	CER.CAPACITOR-S	1000P 50V
C128	QCB1HK-101Y	CAPACITOR	100P 50V
C129	QCB1HK-101Y	CAPACITOR	100P 50V
C130	QCB1HK-102Y	CER.CAPACITOR-S	1000P 50V
C131	QCZ0206-104Z	CER.CAPACITOR-S	0.10
C132	QCZ0206-104Z	CER.CAPACITOR-S	0.10
C133	QCZ0206-104Z	CER.CAPACITOR-S	0.10
C134	QCZ0206-104Z	CER.CAPACITOR-S	0.10
C135	QCB1HK-101Y	CAPACITOR	100P 50V
C136	QCB1HK-101Y	CAPACITOR	100P 50V
C137	QCZ0206-104Z	CER.CAPACITOR-S	0.10
C138	QCB1HK-102Y	CER.CAPACITOR-S	1000P 50V
C141	QETC1EM-476Z	E.CAPACITOR	47 25V
C142	QCZ0206-104Z	CER.CAPACITOR-S	0.10
C143	QETC1EM-227Z	E.CAPACITOR	220 25V
C144	QETC1EM-227Z	E.CAPACITOR	220 25V
C145	QCB1HK-102Y	CER.CAPACITOR-S	1000P 50V
C146	QCZ0206-104Z	CER.CAPACITOR-S	0.10
C150	QCZ0206-104Z	CER.CAPACITOR-S	0.10
L1	QQL01BJ-1R0Z	PEAKING COIL	
L2	SSV3629	SF COIL	
L3	SSV3629	SF COIL	
X1	QAX0286-001	CER.RESONATOR	
F2	QMFZ035-2R0-S	FUSE	
F3	QMFZ035-2R0-S	FUSE	
CN3	QGA2501C1-10	CONNECTOR	
CN110	QGA3901C1-03	CONNECTOR	
CN205	QGA2501C2-06Z	CONNECTOR	
CN420	QGA2501C2-03Z	CONNECTOR	
CN430	QGA2001C1-04	CONNECTOR	
CN500	QGF1003C1-30	CONNECTOR	
CN600	QGA2001C1-10	CONNECTOR	
CN730	QGA2004C1-14S	DF CONNECTOR	
CN740	QGA2004C1-14S	DF CONNECTOR	
CN750	QGA2004C1-14S	DF CONNECTOR	
CN760	QGA2004C1-14S	DF CONNECTOR	

Symbol No.	Part No.	Part Name	Description
CN900	QGA2001C1-15	CONNECTOR	
TP1	QNZ0352-001Z	TEST POINT	
TP2	QNZ0352-001Z	TEST POINT	
TP3	QNZ0352-001Z	TEST POINT	
TP4	QNZ0352-001Z	TEST POINT	
TP5	QNZ0352-001Z	TEST POINT	
TP6	QNZ0352-001Z	TEST POINT	
BT1	SSV2413-002	LITHIUM BATTERY	
K1	QQR0601-001Z	FERRITE BEAD	
K2	QQR0601-001Z	FERRITE BEAD	
K3	QQR0601-001Z	FERRITE BEAD	
K4	QQR0601-001Z	FERRITE BEAD	
K9	QQR0601-001Z	FERRITE BEAD	
K10	QQR0601-001Z	FERRITE BEAD	
K11	QQR0601-001Z	FERRITE BEAD	
K12	QQR0601-001Z	FERRITE BEAD	
K13	QQR0601-001Z	FERRITE BEAD	
K14	QQR0601-001Z	FERRITE BEAD	
K15	QQR0601-001Z	FERRITE BEAD	
K16	QQR0601-001Z	FERRITE BEAD	
K17	QQR0601-001Z	FERRITE BEAD	
K18	QQR0601-001Z	FERRITE BEAD	
K20	QQR0601-001Z	FERRITE BEAD	
K22	QQR0601-001Z	FERRITE BEAD	
K23	QQR0601-001Z	FERRITE BEAD	
K24	QQR0601-001Z	FERRITE BEAD	
K25	QQR0601-001Z	FERRITE BEAD	

5.2 CONNECTOR BOARD ASSEMBLY PARTS LIST

Symbol No.	Part No.	Part Name	Description
LC1	QQR1093-010Z	EMI.FILTER	
LC2	QQR1093-010Z	EMI.FILTER	
LC3	QQR1093-010Z	EMI.FILTER	
LC4	QQR1093-010Z	EMI.FILTER	
LC5	QQR1093-010Z	EMI.FILTER	
LC6	QQR1093-010Z	EMI.FILTER	
LC7	QQR1093-010Z	EMI.FILTER	
LC8	QQR1093-010Z	EMI.FILTER	
CN1	SSV2801	CONNECTOR	
CN4	SSV2801	CONNECTOR	
CN7	QGA3901C1-04	CONNECTOR	
CN120	QGA2501C2-02Z	CONNECTOR	
CN121	QGA2501C2-02Z	CONNECTOR	
CN122	QGA2501C2-02Z	CONNECTOR	
TB1	QNZ0660-001Z	TERMINAL	
TB2	QNZ0660-001Z	TERMINAL	

5.3 RS232C BOARD ASSEMBLY PARTS LIST

Symbol No.	Part No.	Part Name	Description
CN231	QGA2501C1-08	CONNECTOR	
CN232	QNZ0478-001	D-SUB 9P OSU	

5.4 S.MOT BOARD ASSEMBLY PARTS LIST

Symbol No.	Part No.	Part Name	Description
IC1	SLA7026M	I.C.	
IC1	SSV3225	HEAT SINK	
IC1	SS47723-001	SCREW	
IC1	HLG-G746-SI	GREASE	
IC3	LM317HVT	I.C.	
IC3	OSH1625-001	HEAT SINK	
IC3	SS47723-001	SCREW	
IC3	HLG-G746-SI	GREASE	
Q1	2SC3311A/RS-T	SI.TRANSISTOR	MATSUSHITA
Q4	DTC124ESA-T	TRANSISTOR	
D1	ERA15-02-T1	DIODE	FIJI ELECTRIC
R1	QRE141J-561Y	CARBON RESISTOR	560 1/4W
R2	QRE141J-560Y	CARBON RESISTOR	56 1/4W
R3	QRE141J-473Y	CARBON RESISTOR	47K 1/4W
R4	QRE141J-473Y	CARBON RESISTOR	47K 1/4W
R5	QRE141J-222Y	CARBON RESISTOR	2.2K 1/4W
R6	QRE141J-222Y	CARBON RESISTOR	2.2K 1/4W
R7	QRE141J-103Y	CARBON RESISTOR	10K 1/4W
R8	QRE141J-103Y	CARBON RESISTOR	10K 1/4W
R9	QRE141J-470Y	CAROBN RESISTOR	47 1/4W
R10	QRT027J-R22	RESISTOR	0.22 2W
R11	QRT027J-R22	RESISTOR	0.22 2W
R12	QRE141J-121Y	CARBON RESISTOR	120 1/4W
R13	QRE141J-122Y	CARBON RESISTOR	1.2K 1/4W
R14	QRE141J-103Y	CARBON RESISTOR	10K 1/4W
R15	QRE141J-103Y	CARBON RESISTOR	10K 1/4W
C1	QCB31HK-471Z	CAPACITOR	470P 50V
C2	QCB31HK-471Z	CAPACITOR	470P 50V
C3	QCB31HK-222Z	CAPACITOR	2200P 50V
C4	QCB31HK-222Z	CAPACITOR	2200P 50V
C5	QETC1VM-227Z	E CAP	220 35V
C6	QCF31HZ-473	CAPACITOR	0.047 50V
C7	QCB31HK-102Z	C CAP	1000P 50V
C8	QETC1VM-227Z	E CAP	220 35V
C9	QETC1EM-107Z	E.CAPACITOR-CV-	100 25V
RY1	QSK0044-004	RELAY	
CN1	QGA2501C2-06Z	CONNECTOR	
CN2	QGA3901C1-03	CONNECTOR	
CN3	QGA2501C1-10	CONNECTOR	
CN4	QGA3901C1-02	CONNECTOR	

5.5 SCSI BOARD ASSEMBLY PARTS LIST 0 5

0 5 □ □ □ □ □ □ □ □

Symbol No.	Part No.	Part Name	Description	
IC1	HD6413002FP16	CPU		
IC3	PLSS1720	EP-ROM	M27C512-10F1	
IC4	MBM29F200BA-90PF	I.C.		
IC5	TC551001BFL-70L	I.C.	TOSHIBA	
IC7	MC74HC04AN	I.C.(DIGI-MOS)	MOTOROLA	
IC8	MC74HC125AN	I.C.(DIGI-MOS)		
IC9	ICL232CPE	I.C.(MONO-ANA)	INTERSIL	
IC10	ICL232CPE	I.C.(MONO-ANA)	INTERSIL	
IC11	MC74HC04AN	I.C.(DIGI-MOS)	MOTOROLA	
IC12	MC74HC20AP	I.C.(M)	MOTOROLA	
IC13	MC74HCU04AN	M I.C.		
D2	HZS6C2L-T2	ZENER DIODE	HITACHI	
D3	HZS6C2L-T2	ZENER DIODE	HITACHI	
D4	HZS6C2L-T2	ZENER DIODE	HITACHI	
D6	RD33E/B21	ZENER DIODE	SANYO	
D7	ERA82-004-T1	SI.DIODE		
D8	MA700A-T2	DIODE	MATSUSHITA	
D9	ERA82-004-T1	SI.DIODE		
D10	SB140L-6395	SI DIODE		
R1	QRE141J-101Y	CARBON RESISTOR	100	1/4W
R2	QRE141J-101Y	CARBON RESISTOR	100	1/4W
R3	QRE141J-101Y	CARBON RESISTOR	100	1/4W
R4	QRE141J-0R0Y	CARBON RESISTOR	0	1/4W
R5	QRE141J-0R0Y	CARBON RESISTOR	0	1/4W
R17	QRE141J-101Y	CARBON RESISTOR	100	1/4W
R18	QRE141J-101Y	CARBON RESISTOR	100	1/4W
R19	QRE141J-103Y	CARBON RESISTOR	10K	1/4W
R20	QRE141J-103Y	CARBON RESISTOR	10K	1/4W
R21	QRE141J-103Y	CARBON RESISTOR	10K	1/4W
R22	QRE141J-103Y	CARBON RESISTOR	10K	1/4W
R23	QRE141J-103Y	CARBON RESISTOR	10K	1/4W
R25	QRE141J-103Y	CARBON RESISTOR	10K	1/4W
R26	QRE141J-103Y	CARBON RESISTOR	10K	1/4W
R27	QRE141J-101Y	CARBON RESISTOR	100	1/4W
R28	QRE141J-181Y	CARBON RESISTOR	180	1/4W
R31	QRE141J-105Y	CARBON RESISTOR	1.0M	1/4W
R32	QRE141J-391Y	CARBON RESISTOR	390	1/4W
R33	QRE141J-103Y	CARBON RESISTOR	10K	1/4W
R34	QRE141J-103Y	CARBON RESISTOR	10K	1/4W
R35	QRE141J-181Y	CARBON RESISTOR	180	1/4W
R55	QRE141J-331Y	CR	330	1/4W
R56	QRE141J-331Y	CR	330	1/4W
C1	QETC1CM-476Z	AL.E.CAPACITOR	47	16V
C2	QCZ0206-104Z	CER.CAPACITOR-S	0.10	
C5	QCZ0206-104Z	CER.CAPACITOR-S	0.10	
C6	QCZ0206-104Z	CER.CAPACITOR-S	0.10	
C7	QCZ0206-104Z	CER.CAPACITOR-S	0.10	
C8	QETC1EM-226Z	AL.E.CAPACITOR	22	25V
C9	QETC1EM-226Z	AL.E.CAPACITOR	22	25V
C10	QETC1EM-226Z	AL.E.CAPACITOR	22	25V
C11	QETC1EM-226Z	AL.E.CAPACITOR	22	25V
C12	QCZ0206-104Z	CER.CAPACITOR-S	0.10	
C13	QETC1EM-226Z	AL.E.CAPACITOR	22	25V
C14	QETC1EM-226Z	AL.E.CAPACITOR	22	25V
C15	QETC1EM-226Z	AL.E.CAPACITOR	22	25V
C16	QETC1EM-226Z	AL.E.CAPACITOR	22	25V
C21	QCZ0206-104Z	CER.CAPACITOR-S	0.10	
C23	QDC31HJ-330Z	CER.CAPACITOR		
C24	QDC31HJ-330Z	CER.CAPACITOR		
C25	QCZ0206-104Z	CER.CAPACITOR-S	0.10	
C26	QCZ0206-104Z	CER.CAPACITOR-S	0.10	
C27	QCZ0206-104Z	CER.CAPACITOR-S	0.10	
C28	QCZ0206-104Z	CER.CAPACITOR-S	0.10	
C29	QCZ0206-104Z	CER.CAPACITOR-S	0.10	
C30	QCZ0206-104Z	CER.CAPACITOR-S	0.10	
C31	QCZ0206-104Z	CER.CAPACITOR-S	0.10	
C35	QCZ0206-104Z	CER.CAPACITOR-S	0.10	
C36	QCZ0206-104Z	CER.CAPACITOR-S	0.10	
C37	QETC1CM-476Z	AL.E.CAPACITOR	47	16V

Symbol No.	Part No.	Part Name	Description	
C38	QCZ0206-104Z	CER.CAPACITOR-S	0.10	
C39	QCZ0206-104Z	CER.CAPACITOR-S	0.10	
C40	QDC11HJ-220	CAPACITOR		
C41	QDC11HJ-220	CAPACITOR		
C42	QCZ0206-104Z	CER.CAPACITOR-S	0.10	
C50	QCB31HK-102Z	C CAP	1000P	50V
C51	QCB31HK-102Z	C CAP	1000P	50V
LC1	QQR1093-010Z	EMI.FILTER		
LC2	QQR1093-010Z	EMI.FILTER		
LC3	QQR1093-010Z	EMI.FILTER		
LC4	QQR1093-010Z	EMI.FILTER		
LC5	QQR1093-010Z	EMI.FILTER		
LC6	QQR1093-010Z	EMI.FILTER		
LC7	QQR1093-010Z	EMI.FILTER		
LC8	QQR1093-010Z	EMI.FILTER		
LC9	QQR1093-010Z	EMI.FILTER		
LC10	QQR1093-010Z	EMI.FILTER		
LC11	QQR1093-010Z	EMI.FILTER		
LC12	QQR1093-010Z	EMI.FILTER		
LC13	QQR1093-010Z	EMI.FILTER		
LC14	QQR1093-010Z	EMI.FILTER		
LC15	QQR1093-010Z	EMI.FILTER		
LC16	QQR1093-010Z	EMI.FILTER		
LC17	QQR1093-010Z	EMI.FILTER		
LC18	QQR1093-010Z	EMI.FILTER		
LC19	QQR1093-010Z	EMI.FILTER		
LC29	QQR1093-010Z	EMI.FILTER		
LC30	QQR1093-010Z	EMI.FILTER		
LC31	QQR1093-010Z	EMI.FILTER		
X1	QAX0093-001	CRYSTAL		
X2	QAX0025-002Z	CRYSTAL		
F2	QMFZ048-1R0-J1	FUSE		
CN1	QGA2001C1-04	CONNECTOR		
CN13	QGA2501C2-04Z	CONNECTOR		
CN205	QGA2501C2-06Z	CONNECTOR		
CN231	QGA2501C1-08	CONNECTOR		
CN240	SC42462-150	CONNECTOR		
TP1	QNZ0352-001Z	TEST POINT		
TP2	QNZ0352-001Z	TEST POINT		
TP3	QNZ0352-001Z	TEST POINT		
TP4	QNZ0352-001Z	TEST POINT		
BT1	SSV2413-002	LITHIUM BATTERY		
TB1	QNZ0660-001Z	TERMINAL		

5.6 DISPLAY BOARD ASSEMBLY PARTS LIST 0 6

0 6

Symbol No.	Part No.	Part Name	Description
IC1	SN74HC245N	I.C(DIGI-MOS)	TEXAS
IC2	MC74HC04AN	I.C(DIGI-MOS)	MOTOROLA
D1	ERA15-02-T1	DIODE	FIJI ELECTRIC
D2	ERA15-02-T1	DIODE	FIJI ELECTRIC
D3	ERA15-02-T1	DIODE	FIJI ELECTRIC
D4	ERA15-02-T1	DIODE	FIJI ELECTRIC
D5	ERA15-02-T1	DIODE	FIJI ELECTRIC
D6	ERA15-02-T1	DIODE	FIJI ELECTRIC
D7	ERA15-02-T1	DIODE	FIJI ELECTRIC
D8	ERA15-02-T1	DIODE	FIJI ELECTRIC
D9	ERA15-02-T1	DIODE	FIJI ELECTRIC
D10	ERA15-02-T1	DIODE	FIJI ELECTRIC
D11	ERA15-02-T1	DIODE	FIJI ELECTRIC
D12	ERA15-02-T1	DIODE	FIJI ELECTRIC
D13	ERA15-02-T1	DIODE	FIJI ELECTRIC
D14	ERA15-02-T1	DIODE	FIJI ELECTRIC
LD1	SLR-56MG3F	L.E.D.	
R1	QRE141J-122Y	CARBON RESISTOR	1.2K 1/4W
R2	QRE141J-153Y	CARBON RESISTOR	15K 1/4W
R3	QRE141J-271Y	CARBON RESISTOR	270 1/4W
C1	QCZ0206-104Z	CER.CAPACITOR-S	0.10
C2	QCZ0206-104Z	CER.CAPACITOR-S	0.10
C3	QCZ0206-104Z	CER.CAPACITOR-S	0.10
S1	QSW0178-001	TACT SWICH	
S2	QSW0178-001	TACT SWICH	
S3	QSW0178-001	TACT SWICH	
S4	QSW0178-001	TACT SWICH	
S5	QSW0178-001	TACT SWICH	
S6	QSW0178-001	TACT SWICH	
S7	QSW0178-001	TACT SWICH	
S8	QSW0178-001	TACT SWICH	
S9	QSW0178-001	TACT SWICH	
S10	QSW0178-001	TACT SWICH	
S11	QSW0178-001	TACT SWICH	
S12	QSW0178-001	TACT SWICH	
S13	QSW0178-001	TACT SWICH	
S14	QSW0178-001	TACT SWICH	
CN2	QGG2508M1-16	POST HEADER	
CN900	QGA2001F1-15	CONNECTOR	
	QLD0276-001	LCD MODULE	
	QYSDSP2004N	SCREW	

5.7 MAIL CN BOARD ASSEMBLY PARTS LIST 0 7

0 7

Symbol No.	Part No.	Part Name	Description
CN1	QGA2001C1-10	CONNECTOR	
CN600	QGA2001C1-10	CONNECTOR	

5.8 ROT SENSEOR BOARD ASSEMBLY PARTS LIST 0 8

0 8

Symbol No.	Part No.	Part Name	Description
IC430	GP1A33R	I.C(PH.INTER.)	
R430	QRE141J-101Y	CARBON RESISTOR	100 1/4W
CN430	QGA2001C1-04	CONNECTOR	

5.9 MG SENSOR BOARD ASSEMBLY PARTS LIST 0 9

0 9

Symbol No.	Part No.	Part Name	Description
CN1	QGA2001C1-04	CONNECTOR	
CN101	QGA2501C2-03Z	CONNECTOR	
CN102	QGA2501C2-03Z	CONNECTOR	

5.10 CARRIER MEC BOARD ASSEMBLY PARTS LIST 1 0

1 0 □ □ □ □ □ □ □ □

Symbol No.	Part No.	Part Name	Description
Q801	2SC3311A/RS-T	SI.TRANSISTOR	MATSUSHITA
D801	HZS5CLL-T2	BARICAP DIODE	HITACHI
LD21	SEL6210R-T	L.E.D.	
LD22	SEL6410G-T	L.E.D.	
LD30	SEL6210R-T	L.E.D.	
LD31	SEL6410G-T	L.E.D.	
LD40	SEL6410G-T	L.E.D.	
LD41	SEL6210R-T	L.E.D.	
LD50	SEL6410G-T	L.E.D.	
LD51	SEL6210R-T	L.E.D.	
LD52	SEL6410G-T	L.E.D.	
LD60	SEL6210R-T	L.E.D.	
LD61	SEL6410G-T	L.E.D.	
LD70	SEL6410G-T	L.E.D.	
LD71	SEL6210R-T	L.E.D.	
LD80	SEL6410G-T	L.E.D.	
R211	QRE141J-821Y	CARBON RESISTOR	820 1/4W
R212	QRE141J-101Y	CARBON RESISTOR	100 1/4W
R221	QRE141J-821Y	CARBON RESISTOR	820 1/4W
R222	QRE141J-101Y	CARBON RESISTOR	100 1/4W
R301	QRE141J-821Y	CARBON RESISTOR	820 1/4W
R302	QRE141J-101Y	CARBON RESISTOR	100 1/4W
R303	QRE141J-101Y	CARBON RESISTOR	100 1/4W
R304	QRE141J-821Y	CARBON RESISTOR	820 1/4W
R401	QRE141J-821Y	CARBON RESISTOR	820 1/4W
R402	QRE141J-101Y	CARBON RESISTOR	100 1/4W
R403	QRE141J-103Y	CARBON RESISTOR	10K 1/4W
R411	QRE141J-821Y	CARBON RESISTOR	820 1/4W
R412	QRE141J-101Y	CARBON RESISTOR	100 1/4W
R413	QRE141J-103Y	CARBON RESISTOR	10K 1/4W
R501	QRE141J-821Y	CARBON RESISTOR	820 1/4W
R502	QRE141J-101Y	CARBON RESISTOR	100 1/4W
R511	QRE141J-821Y	CARBON RESISTOR	820 1/4W
R512	QRE141J-101Y	CARBON RESISTOR	100 1/4W
R521	QRE141J-821Y	CARBON RESISTOR	820 1/4W
R522	QRE141J-101Y	CARBON RESISTOR	100 1/4W
R601	QRE141J-222Y	CARBON RESISTOR	2.2K 1/4W
R611	QRE141J-222Y	CARBON RESISTOR	2.2K 1/4W
R701	QRE141J-821Y	CARBON RESISTOR	820 1/4W
R702	QRE141J-101Y	CARBON RESISTOR	100 1/4W
R711	QRE141J-821Y	CARBON RESISTOR	820 1/4W
R712	QRE141J-101Y	CARBON RESISTOR	100 1/4W
R801	QRE141J-102Y	CARBON RESISTOR	1.0K 1/4W
R802	QRE141J-221Y	CARBON RESISTOR	220 1/4W
R803	QRE141J-103Y	CARBON RESISTOR	10K 1/4W
R804	QRE141J-103Y	CARBON RESISTOR	10K 1/4W
R805	QRE141J-102Y	CARBON RESISTOR	1.0K 1/4W
R901	QRE141J-101Y	CARBON RESISTOR	100 1/4W
R911	QRE141J-101Y	CARBON RESISTOR	100 1/4W
C202	QCFB1HZ-473Y	CER.CAPACITOR-S	0.047 50V
C211	QDYB1CM-103Y	C CAP	
C221	QDYB1CM-103Y	C CAP	
C222	QCFB1HZ-473Y	CER.CAPACITOR-S	0.047 50V
C301	QDYB1CM-103Y	C CAP	
C302	QCFB1HZ-473Y	CER.CAPACITOR-S	0.047 50V
C303	QDYB1CM-103Y	C CAP	
C401	QCB1HK-102Y	CER.CAPACITOR-S	1000P 50V
C402	QCFB1HZ-473Y	CER.CAPACITOR-S	0.047 50V
C411	QCB1HK-102Y	CER.CAPACITOR-S	1000P 50V
C501	QDYB1CM-103Y	C CAP	
C502	QCFB1HZ-473Y	CER.CAPACITOR-S	0.047 50V
C511	QDYB1CM-103Y	C CAP	
C521	QDYB1CM-103Y	C CAP	
C601	QDYB1CM-103Y	C CAP	
C611	QDYB1CM-103Y	C CAP	
C701	QDYB1CM-103Y	C CAP	
C702	QCFB1HZ-473Y	CER.CAPACITOR-S	0.047 50V

Symbol No.	Part No.	Part Name	Description
C711	QDYB1CM-103Y	C CAP	
C712	QCFB1HZ-473Y	CER.CAPACITOR-S	0.047 50V
C801	QCFB1HZ-473Y	CER.CAPACITOR-S	0.047 50V
C802	QCFB1HZ-473Y	CER.CAPACITOR-S	0.047 50V
C901	QCFB1HZ-473Y	CER.CAPACITOR-S	0.047 50V
C902	QCFB1HZ-473Y	CER.CAPACITOR-S	0.047 50V
C903	QER61CM-107Z	E.CAPACITOR	100 16V
C911	QCFB1HZ-473Y	CER.CAPACITOR-S	0.047 50V
C912	QER60JM-107Z	AL.E.CAPACITOR	100 6.3V
CN19	QGF1004F1-30	CONNECTOR	
CN20	QGA2001F1-03	CONNECTOR	JVC
CN22	QGA2001F1-03	CONNECTOR	
CN30	QGA2501F1-04	CONNECTOR	
CN40	QGA2001F1-04	CONNECTOR	
CN50	QGA2001F1-05	CONNECTOR	
CN70	QGA2501F1-03	CONNECTOR	
CN71	QGA2501F1-03	CONNECTOR	
CN80	QGA2501F1-02	CONNECTOR	
CN83	QGA2001F1-02	CONNECTOR	
CN90	QGA2501F1-02	CONNECTOR	
CN91	QGA2501F1-02	CONNECTOR	
TP80	QNZ0352-001Z	TEST POINT	
TP91	QNZ0352-001Z	TEST POINT	

5.11 R CATCH BOARD ASSEMBLY PARTS LIST 1 1

1 1 □ □ □ □ □ □ □ □

Symbol No.	Part No.	Part Name	Description
PC21	GP1A53E	I.C(PH.INTER)	
R213	QRE141J-391Y	CARBON RESISTOR	390 1/4W
R214	QRE141J-271Y	CARBON RESISTOR	270 1/4W
CN20	QGA2001F1-03	CONNECTOR	

5.12 L CATCH BOARD ASSEMBLY PARTS LIST 1 2

1 2 □ □ □ □ □ □ □ □

Symbol No.	Part No.	Part Name	Description
PC22	GP1A53E	I.C(PH.INTER)	
R223	QRE141J-391Y	CARBON RESISTOR	390 1/4W
R224	QRE141J-271Y	CARBON RESISTOR	270 1/4W
CN22	QGA2001F1-03	CONNECTOR	

5.13 LOADING BOARD ASSEMBLY PARTS LIST 1 3

1 3

Symbol No.	Part No.	Part Name	Description	
PC40	GP1A33R	I.C(PH.INTER.)		
R403	QRE141J-101Y	CARBON RESISTOR	100	1/4W
CN40	QGA2001C1-04	CONNECTOR		

5.16 L ADD BOARD ASSEMBLY PARTS LIST 1 6

1 6

Symbol No.	Part No.	Part Name	Description	
PC70	GP1A53E	I.C(PH.INTER)		
R703 R704	QRE141J-391Y QRE141J-271Y	CARBON RESISTOR CARBON RESISTOR	390 270	1/4W 1/4W
CN70	QGA2501F1-03	CONNECTOR		

5.14 TRAY LOCK BOARD ASSEMBLY PARTS LIST 1 4

1 4

Symbol No.	Part No.	Part Name	Description	
PC50 PC51 PC52	GP1A53E GP1A53E GP1A53E	I.C(PH.INTER) I.C(PH.INTER) I.C(PH.INTER)		
R503	QRE141J-391Y	CARBON RESISTOR	390	1/4W
R504	QRE141J-271Y	CARBON RESISTOR	270	1/4W
R513	QRE141J-391Y	CARBON RESISTOR	390	1/4W
R514	QRE141J-271Y	CARBON RESISTOR	270	1/4W
R523	QRE141J-391Y	CARBON RESISTOR	390	1/4W
R524	QRE141J-271Y	CARBON RESISTOR	270	1/4W
CN50	QGA2001F1-05	CONNECTOR		

5.17 R ADD BOARD ASSEMBLY PARTS LIST 1 7

1 7

Symbol No.	Part No.	Part Name	Description	
PC71	GP1A53E	I.C(PH.INTER)		
R713 R714	QRE141J-391Y QRE141J-271Y	CARBON RESISTOR CARBON RESISTOR	390 270	1/4W 1/4W
CN71	QGA2501F1-03	CONNECTOR		

5.15 LANE2 SEN BOARD ASSEMBLY PARTS LIST 1 5

1 5

Symbol No.	Part No.	Part Name	Description	
PC1 PC2	GP1A53E GP1A53E	I.C(PH.INTER) I.C(PH.INTER)		
R302	QRE141J-271Y	CARBON RESISTOR	270	1/4W
R303	QRE141J-221Y	CARBON RESISTOR	220	1/4W
R304	QRE141J-271Y	CARBON RESISTOR	270	1/4W
CN30	QGA2501F1-04	CONNECTOR	JVC	

5.18 DISC SEN R BOARD ASSEMBLY PARTS LIST 1 8

1 8

Symbol No.	Part No.	Part Name	Description	
PC80 PC80	PT381F SC43656-015	PH TRANSISTOR LED SPACER		
CN80	QGA2501F1-02	CONNECTOR		

5.19 DISC SENSITIVE BOARD ASSEMBLY PARTS LIST 1 9

1 9

Symbol No.	Part No.	Part Name	Description
R805	QRE141J-391Y	CARBON RESISTOR	390 1/4W
CN83	QGA2001F1-02	CONNECTOR	
PD80 PD80	GL381 SC43656-015	L.E.D. LED SPACER	

5.20 MAIL SLOT BOARD ASSEMBLY PARTS LIST 2 0

2 0

Symbol No.	Part No.	Part Name	Description
Q1 Q2	2SC3311A/RS/ 2SC3311A/RS/	SI.TRANSISTOR SI.TRANSISTOR	
D1 D2	HZS5CLL-T2 HZS5CLL-T2	BARICAP DIODE BARICAP DIODE	HITACHI HITACHI
LD1 LD1 LD2 LD2	GL381 SC43656-015 GL381 SC43656-015	L.E.D. LED SPACER L.E.D. LED SPACER	
R2	QRE141J-103Y	CARBON RESISTOR	10K 1/4W
R3	QRE141J-391Y	CARBON RESISTOR	390 1/4W
R4	QRE141J-391Y	CARBON RESISTOR	390 1/4W
R5	QRE141J-221Y	CARBON RESISTOR	220 1/4W
R6	QRE141J-221Y	CARBON RESISTOR	220 1/4W
R7	QRE141J-103Y	CARBON RESISTOR	10K 1/4W
R8	QRE141J-103Y	CARBON RESISTOR	10K 1/4W
R9	QRE141J-103Y	CARBON RESISTOR	10K 1/4W
R10	QRE141J-103Y	CARBON RESISTOR	10K 1/4W
R11	QRE141J-102Y	CARBON RESISTOR	1.0K 1/4W
R12	QRE141J-102Y	CARBON RESISTOR	1.0K 1/4W
C1	QCFB1HZ-473Y	CER.CAPACITOR-S	0.047 50V
C3	QCFB1HZ-473Y	CER.CAPACITOR-S	0.047 50V
C4	QCFB1HZ-473Y	CER.CAPACITOR-S	0.047 50V
C5	QCFB1HZ-473Y	CER.CAPACITOR-S	0.047 50V
CN1 CN2 CN3 CN4 CN6	QGA2001F1-10 QGA2005F1-03 QGA2501F1-02 QGA2501F1-04 QGA2501F1-03	CONNECTOR CONNECTOR CONNECTOR CONNECTOR CONNECTOR	JVC

5.21 SENSOR BOARD ASSEMBLY PARTS LIST 2 1

2 1

Symbol No.	Part No.	Part Name	Description
C1 C2	QCFB1HZ-473Y QCFB1HZ-473Y	CER.CAPACITOR-S CER.CAPACITOR-S	0.047 50V 0.047 50V
CN41	QGA2501F1-04	CONNECTOR	JVC
PT1 PT1 PT2 PT2	PT381F SC43656-015 PT381F SC43656-015	PH TRANSISTOR LED SPACER PH TRANSISTOR LED SPACER	

5.22 POSITIVE BOARD ASSEMBLY PARTS LIST 2 2

2 2

Symbol No.	Part No.	Part Name	Description
PC61	GP1A53E	I.C(PH.INTER)	
R61 R62	QRE141J-271Y QRE141J-391Y	CARBON RESISTOR CARBON RESISTOR	270 1/4W 390 1/4W
CN6	QGA2501F1-03	CONNECTOR	

5.23 LVD BOARD ASSEMBLY PARTS LIST 2 3

SK250400A1

2 3

Symbol No.	Part No.	Part Name	Description	
IC1	LSI53C180192BGA	I.C.		
IC2	DS21T05Z-X	I.C.		
IC3	DS21T05Z-X	I.C.		
IC4	DS21T05Z-X	I.C.		
IC9	SI-3033LSA-X	I.C.		
IC10	TC4S69F-X	I.C.(M)	TOSHIBA	
Q1	MSD1819A/R/-X	SI.TRANSISTOR	MOTOROLA	
Q2	MSD1819A/R/-X	SI.TRANSISTOR	MOTOROLA	
D1	MA738-X	DIODE	MATSUSHITA	
D3	MA738-X	DIODE	MATSUSHITA	
R1	NRSA63J-0R0X	M.G.RESISTOR	0	1/16W
R2	NRSA63J-0R0X	M.G.RESISTOR	0	1/16W
R3	NRSA63J-472X	M.G.RESISTOR	4.7K	1/16W
R4	NRSA63J-0R0X	M.G.RESISTOR	0	1/16W
R6	NRSA63J-103X	M.G.RESISTOR	10K	1/16W
R7	NRSA63J-103X	M.G.RESISTOR	10K	1/16W
R8	NRSA63J-103X	M.G.RESISTOR	10K	1/16W
R9	NRSA63J-0R0X	M.G.RESISTOR	0	1/16W
R10	NRSA63J-0R0X	M.G.RESISTOR	0	1/16W
R11	NRSA63J-103X	M.G.RESISTOR	10K	1/16W
R12	NRSA63J-472X	M.G.RESISTOR	4.7K	1/16W
R13	NRSA63J-274X	M.G.RESISTOR	270K	1/16W
R14	NRSA63J-223X	M.G.RESISTOR	22K	1/16W
R15	NRSA63J-150X	MGR	15	1/16W
R16	NRSA63J-103X	M.G.RESISTOR	10K	1/16W
R17	NRSA63J-103X	M.G.RESISTOR	10K	1/16W
R18	NRSA63J-472X	M.G.RESISTOR	4.7K	1/16W
R21	NRSA63J-0R0X	M.G.RESISTOR	0	1/16W
R22	NRSA63J-472X	M.G.RESISTOR	4.7K	1/16W
R23	NRSA63J-0R0X	M.G.RESISTOR	0	1/16W
R24	NRSA63J-0R0X	M.G.RESISTOR	0	1/16W
R25	NRSA63J-0R0X	M.G.RESISTOR	0	1/16W
R26	NRSA63J-0R0X	M.G.RESISTOR	0	1/16W
R27	NRSA63J-0R0X	M.G.RESISTOR	0	1/16W
R28	NRSA63J-103X	M.G.RESISTOR	10K	1/16W
R29	NRSA63J-0R0X	M.G.RESISTOR	0	1/16W
R30	NRSA63J-0R0X	M.G.RESISTOR	0	1/16W
R31	NRSA63J-0R0X	M.G.RESISTOR	0	1/16W
R32	NRSA63J-0R0X	M.G.RESISTOR	0	1/16W
R33	NRSA63J-0R0X	M.G.RESISTOR	0	1/16W
R36	NRSA63J-0R0X	M.G.RESISTOR	0	1/16W
C1	NCF31EZ-104X	CER.CAPACITOR	0.10	25V
C2	NCF31EZ-104X	CER.CAPACITOR	0.10	25V
C3	NCF31EZ-104X	CER.CAPACITOR	0.10	25V
C5	NEHM1EM-475X	AL E.CAPACITOR	4.7	25V
C6	NCF31EZ-104X	CER.CAPACITOR	0.10	25V
C10	NCF31EZ-104X	CER.CAPACITOR	0.10	25V
C12	NEHM0JM-476X	AL E.CAPACITOR	47	6.3V
C14	NEHM0JM-476X	AL E.CAPACITOR	47	6.3V
C15	NEHM0JM-476X	AL E.CAPACITOR	47	6.3V
C16	NEHM1EM-475X	AL E.CAPACITOR	4.7	25V
C17	NCF31EZ-104X	CER.CAPACITOR	0.10	25V
C18	NCF31EZ-104X	CER.CAPACITOR	0.10	25V
C19	NCF31EZ-104X	CER.CAPACITOR	0.10	25V
C20	NCF31EZ-104X	CER.CAPACITOR	0.10	25V
C21	NEHM1EM-475X	AL E.CAPACITOR	4.7	25V
C22	NCB31HK-103X	C CAP	0.010	50V
C23	NCF31EZ-104X	CER.CAPACITOR	0.10	25V
C24	NCF31EZ-104X	CER.CAPACITOR	0.10	25V
C25	NCF31EZ-104X	CER.CAPACITOR	0.10	25V
C26	NCF31EZ-104X	CER.CAPACITOR	0.10	25V
C27	NCF31EZ-104X	CER.CAPACITOR	0.10	25V
C28	NEHM1EM-475X	AL E.CAPACITOR	4.7	25V
C29	NCF31EZ-104X	CER.CAPACITOR	0.10	25V
C30	NCF31EZ-104X	CER.CAPACITOR	0.10	25V
C31	NCF31EZ-104X	CER.CAPACITOR	0.10	25V
C32	NCF31EZ-104X	CER.CAPACITOR	0.10	25V

Symbol No.	Part No.	Part Name	Description	
C33	NCF31EZ-104X	CER.CAPACITOR	0.10	25V
C34	NCF31EZ-104X	CER.CAPACITOR	0.10	25V
C35	NCF31EZ-104X	CER.CAPACITOR	0.10	25V
C38	NCF31EZ-104X	CER.CAPACITOR	0.10	25V
C40	NEHM0JM-107X	AL E.CAPACITOR	100	6.3V
C41	NEHM1EM-475X	AL E.CAPACITOR	4.7	25V
C44	NCF31EZ-104X	CER.CAPACITOR	0.10	25V
C45	NCF31EZ-104X	CER.CAPACITOR	0.10	25V
C46	NCF31EZ-104X	CER.CAPACITOR	0.10	25V
C47	NEHM0JM-226X	AL E.CAPACITOR	22	6.3V
C48	NCF31EZ-104X	CER.CAPACITOR	0.10	25V
C49	NCF31EZ-104X	CER.CAPACITOR	0.10	25V
C50	NEHM1CM-226X	AL E.CAPACITOR	22	16V
C52	NCF31EZ-104X	CER.CAPACITOR	0.10	25V
C53	NCF31EZ-104X	CER.CAPACITOR	0.10	25V
C54	NCF31EZ-104X	CER.CAPACITOR	0.10	25V
C55	NEHM0JM-476X	AL E.CAPACITOR	47	6.3V
C56	NEHM0JM-476X	AL E.CAPACITOR	47	6.3V
C57	NEHM0JM-476X	AL E.CAPACITOR	47	6.3V
C58	NEHM0JM-476X	AL E.CAPACITOR	47	6.3V
C59	NCF31EZ-104X	CER.CAPACITOR	0.10	25V
X1	NAX0432-001X	CRYSTAL		
F1	NAD0023-002X	POLI SW		
F2	NAD0024-001X	SWITCH		
F3	NAD0024-001X	SWITCH		
S1	NSW0042-002X	DIP SW		
CN1	QGB1234K1-68	B TO B CONNE		
CN3	SSV2800-50	CONNECTOR		
CN5	QGA2501C1-06	CONNECTOR		
CN6	QGA2501C1-06	CONNECTOR		
K1	NQR0200-001X	CHIP FEL		
K3	NQR0200-001X	CHIP FEL		
K5	NQR0200-001X	CHIP FEL		
K7	NQR0200-001X	CHIP FEL		
K8	NQR0200-001X	CHIP FEL		
K9	NQR0200-001X	CHIP FEL		
K12	NQR0200-001X	CHIP FEL		
K13	NQR0200-001X	CHIP FEL		
K14	NQR0200-001X	CHIP FEL		
K15	NQR0200-001X	CHIP FEL		
K16	NQR0200-001X	CHIP FEL		
K17	NQR0200-001X	CHIP FEL		
K18	NQR0200-001X	CHIP FEL		
TP1	NNZ0009-001X	TEST POINT		
TP2	NNZ0009-001X	TEST POINT		
TP3	NNZ0009-001X	TEST POINT		

SECTION 6 PACKING

6.1 PACKING ASSEMBLY M 7

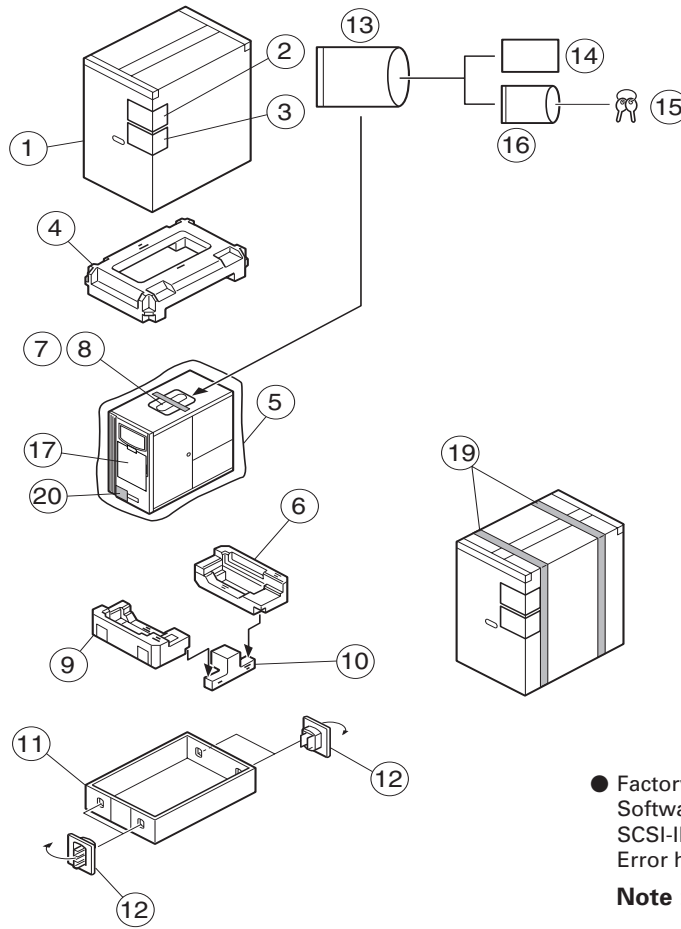

- Factory setting
- Software setting
- SCSI-ID of main unit --- 0
- Error history ----- Clear

Note : Accessories above are subject to change without notice.

6.1.2 PACKING ASSEMBLY PARTS LIST M 7

M 7 M M

Symbol No.	Part No.	Part Name	Description
	1	SS23037-001	PACKING CASE
	2	SS35480	PACKING LABEL
	3	SS32090-004	ROLL LBL SHEET
	4	SS23039-001	CUSHION(T)
	5	SS35453-006	POLY COVER
△	6	SS23041-001	CUSHION(R)
	7	QMP1C08-250	POWER CORD
	8	QMPL018-250-R	POWER CORD
	9	SS23040-001	CUSHION(F)
	10	SS35970-001	CUSHION(S)
	11	SS23013-001	BOTTOM CASE
	12	SSV3282-001	JOINT
	13	QPA02503505	POLY BAG
	14	LST0170-001A	INSTRUCTION
	15	SS47919-00B	KEY ASSEMBLY
	16	QPA00500705	POLY BAG
	17	LST0096-001A	C-SHEET
	19	SSV2250	BAND
	20	SS412715-001	W. LABEL

SECTION 3 DIAGRAMS AND CIRCUIT BOARDS

3.1 CD/DVD LIBRARY BLOCK DIAGRAM

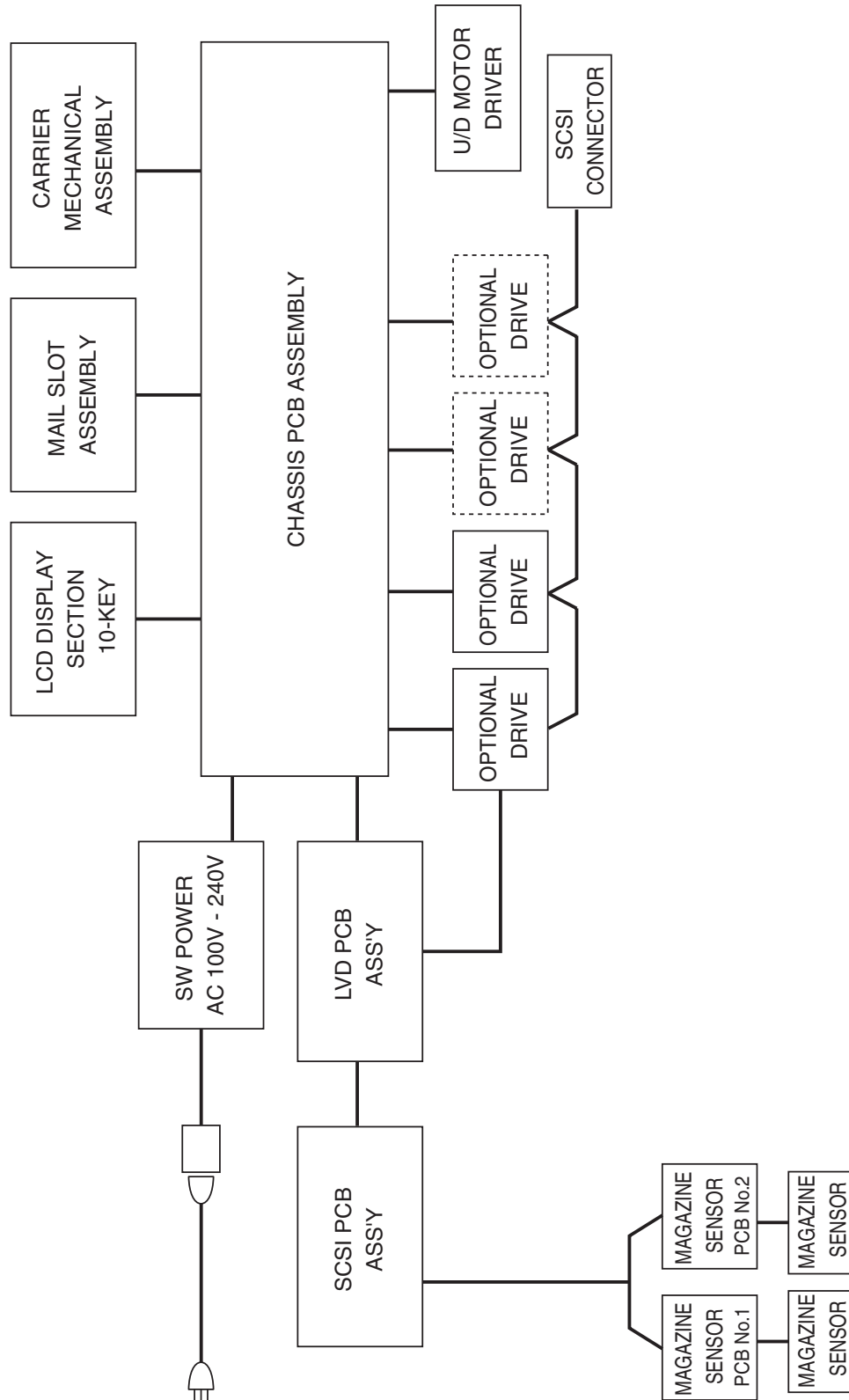

3.2 CHASSIS BLOCK DIAGRAM

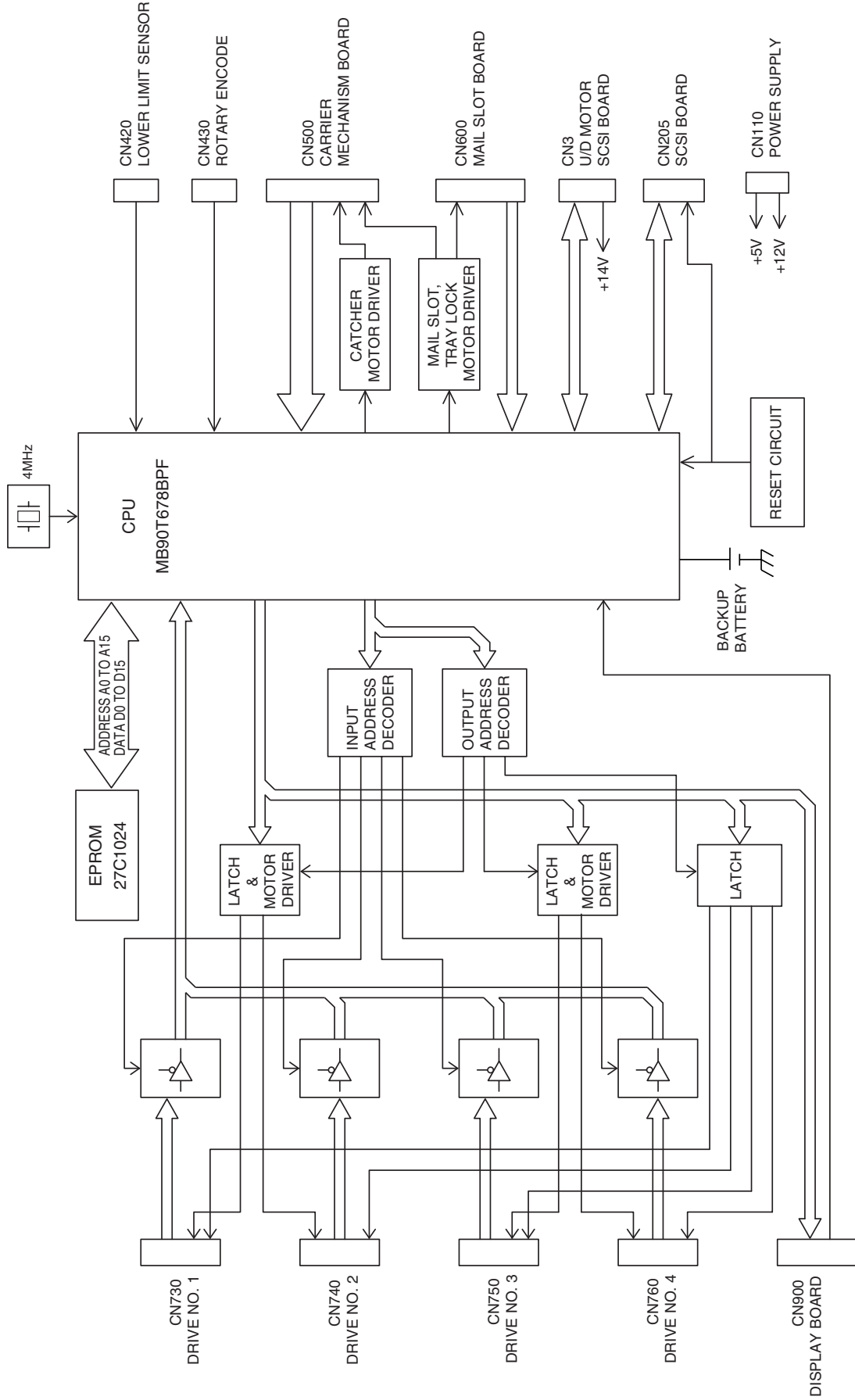

3.3 OVERALL WIRING DIAGRAM

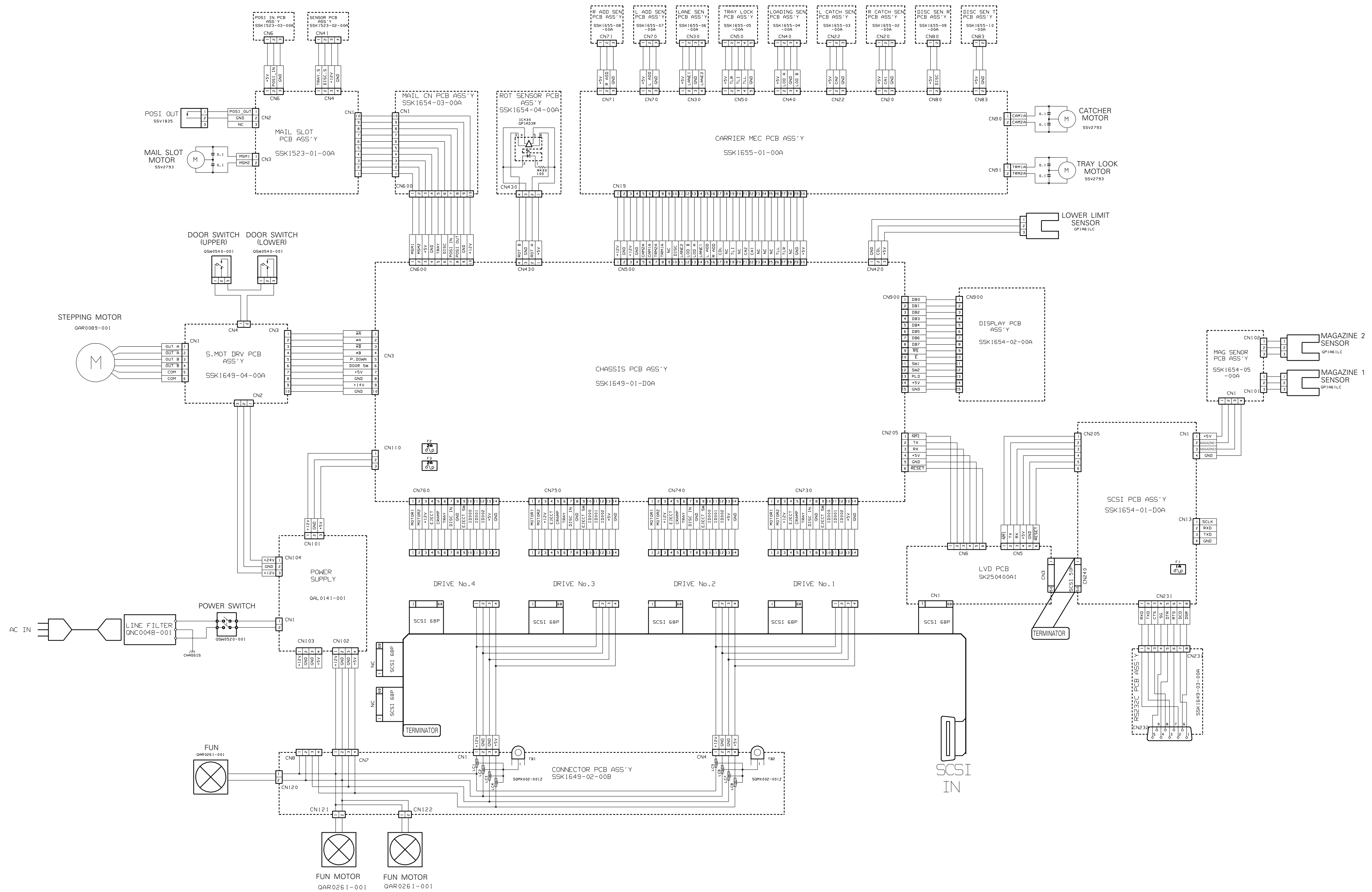

3.4 CHASSIS SCHEMATIC DIAGRAM

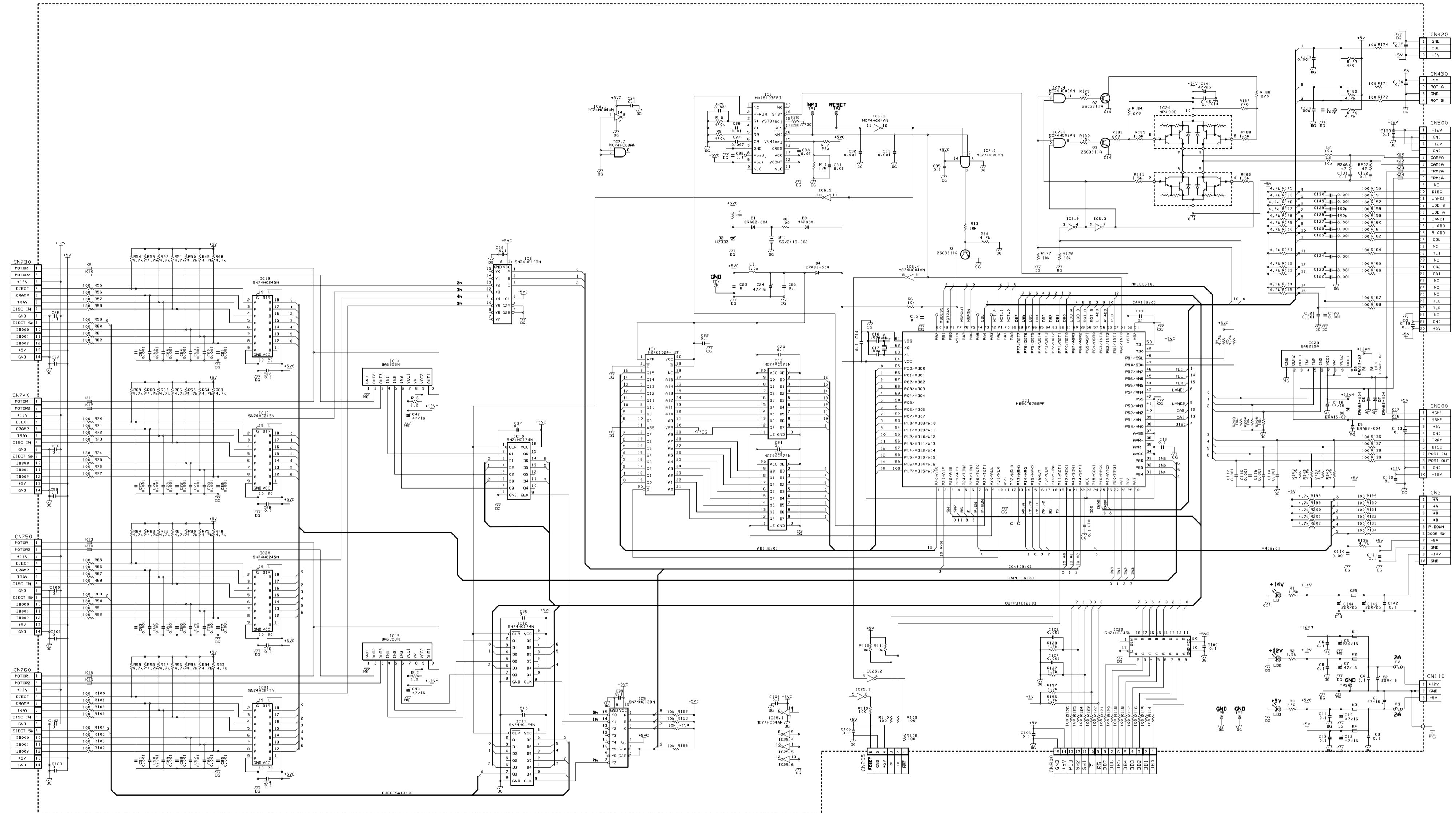

3.5 CHASSIS CIRCUIT BOARD

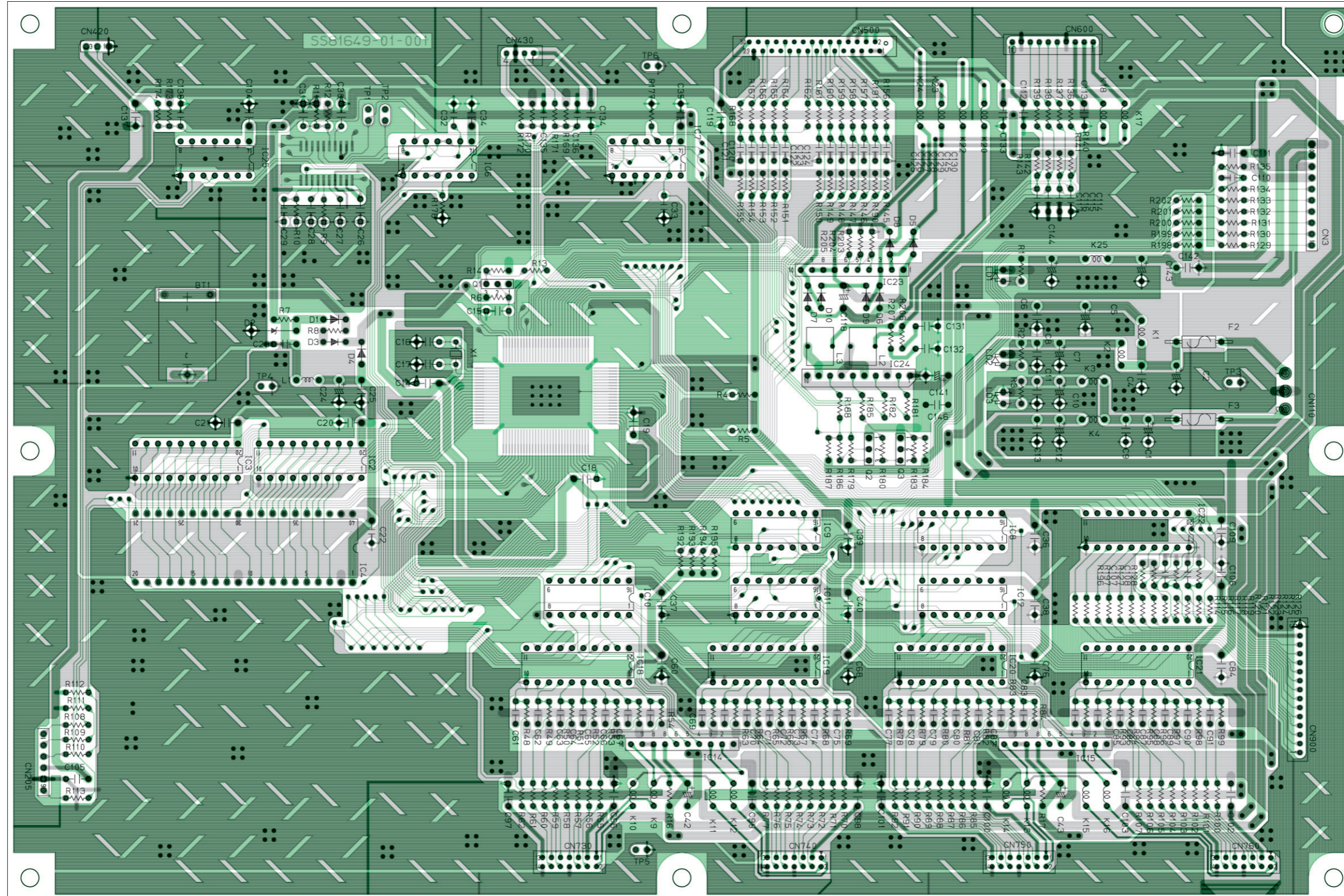

3.6 SCSI SCHEMATIC DIAGRAM

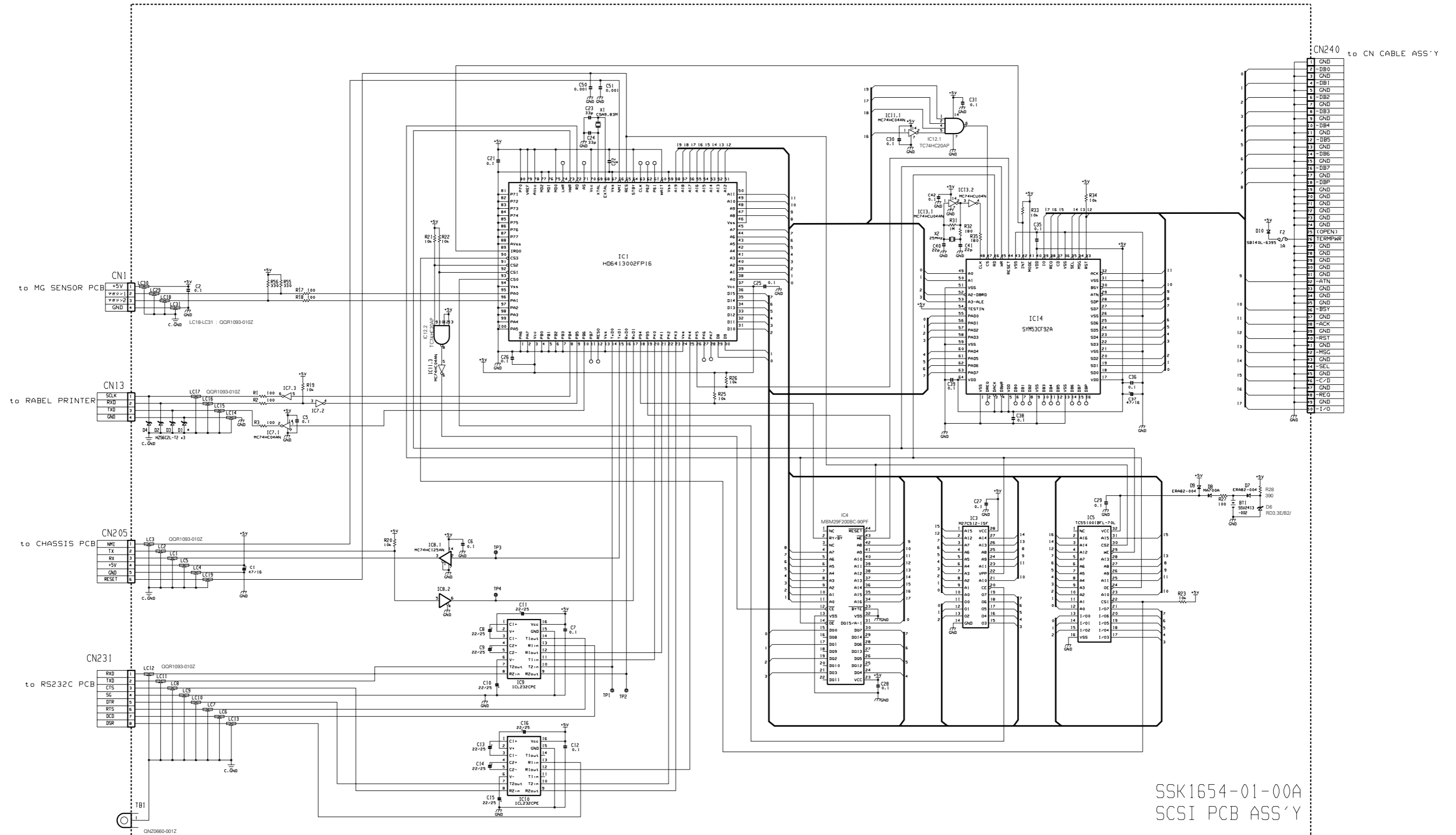

SSK1654-01-00A
SCSI PCB ASS'Y

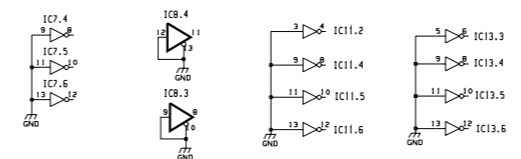

3.7 SCSI CIRCUIT BOARD

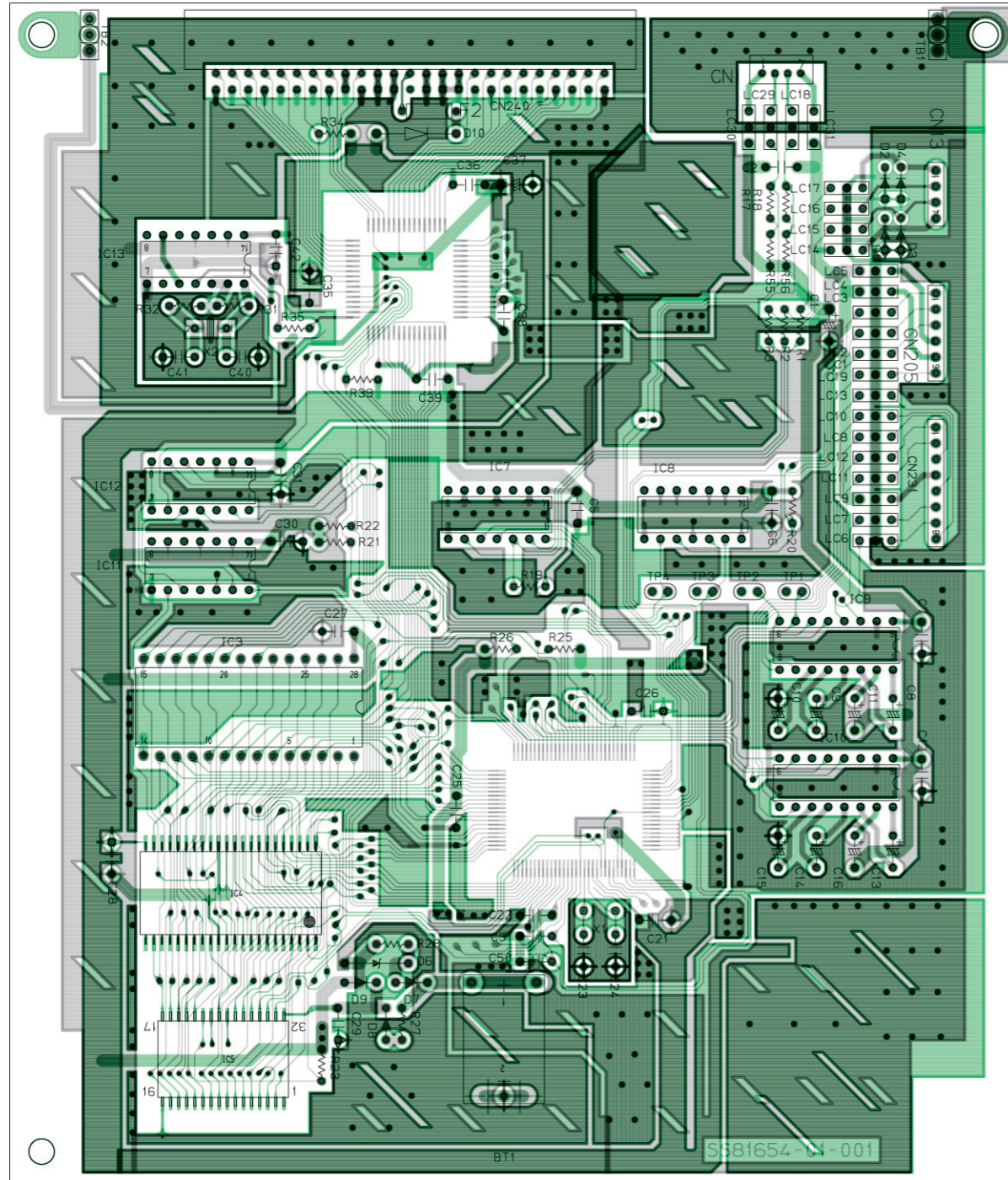

3.8 CARRIER SCHEMATIC DIAGRAM

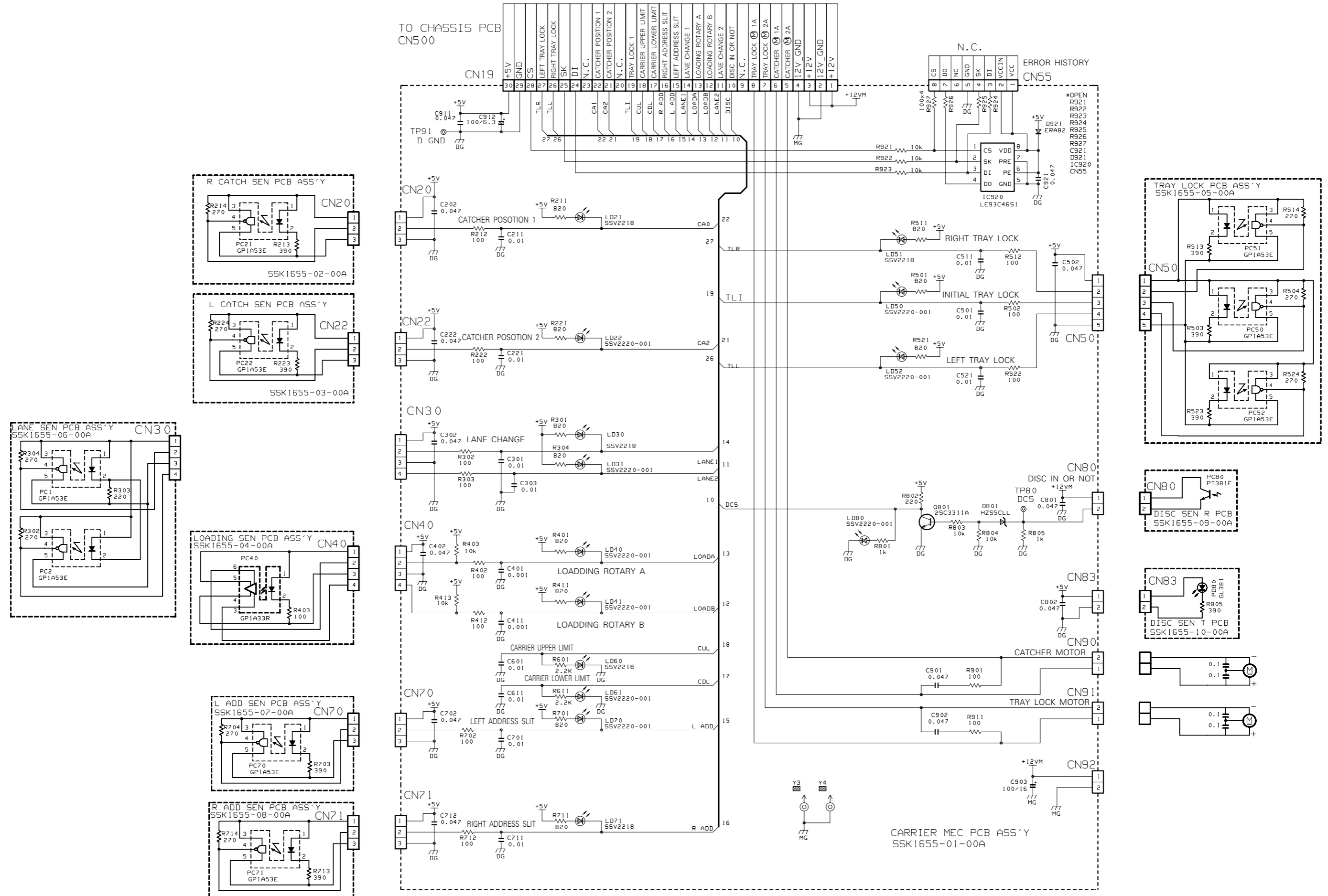

3.9 CARRIER CIRCUIT BOARD

■CARRIER

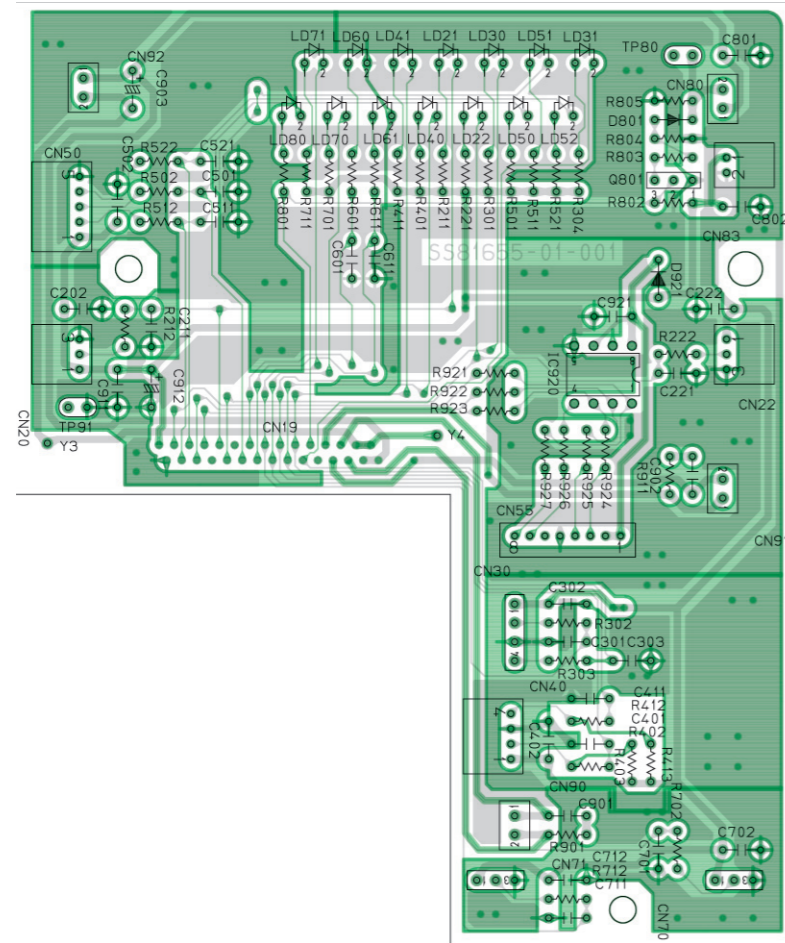

■DISC SEN R

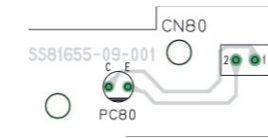

■DISC SEN L

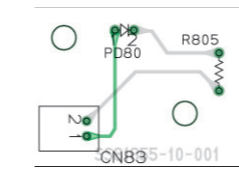

■R ADD

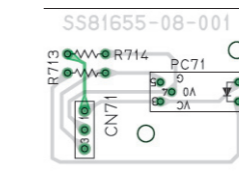

■TRAY LOCK

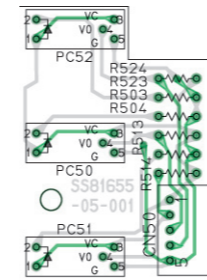

■LANE SEN

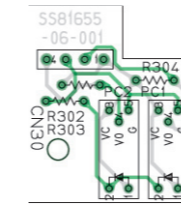

■R CATCH

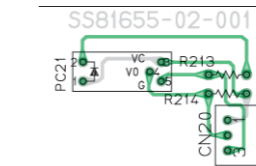

■LOADING SEN

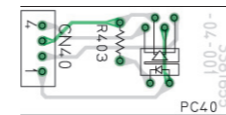

■L ADD

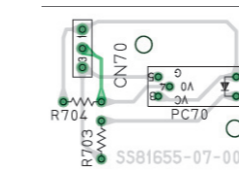

■L CATCH

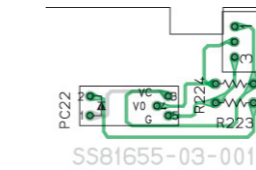

3.10 MAIL SLOT SCHEMATIC DIAGRAM

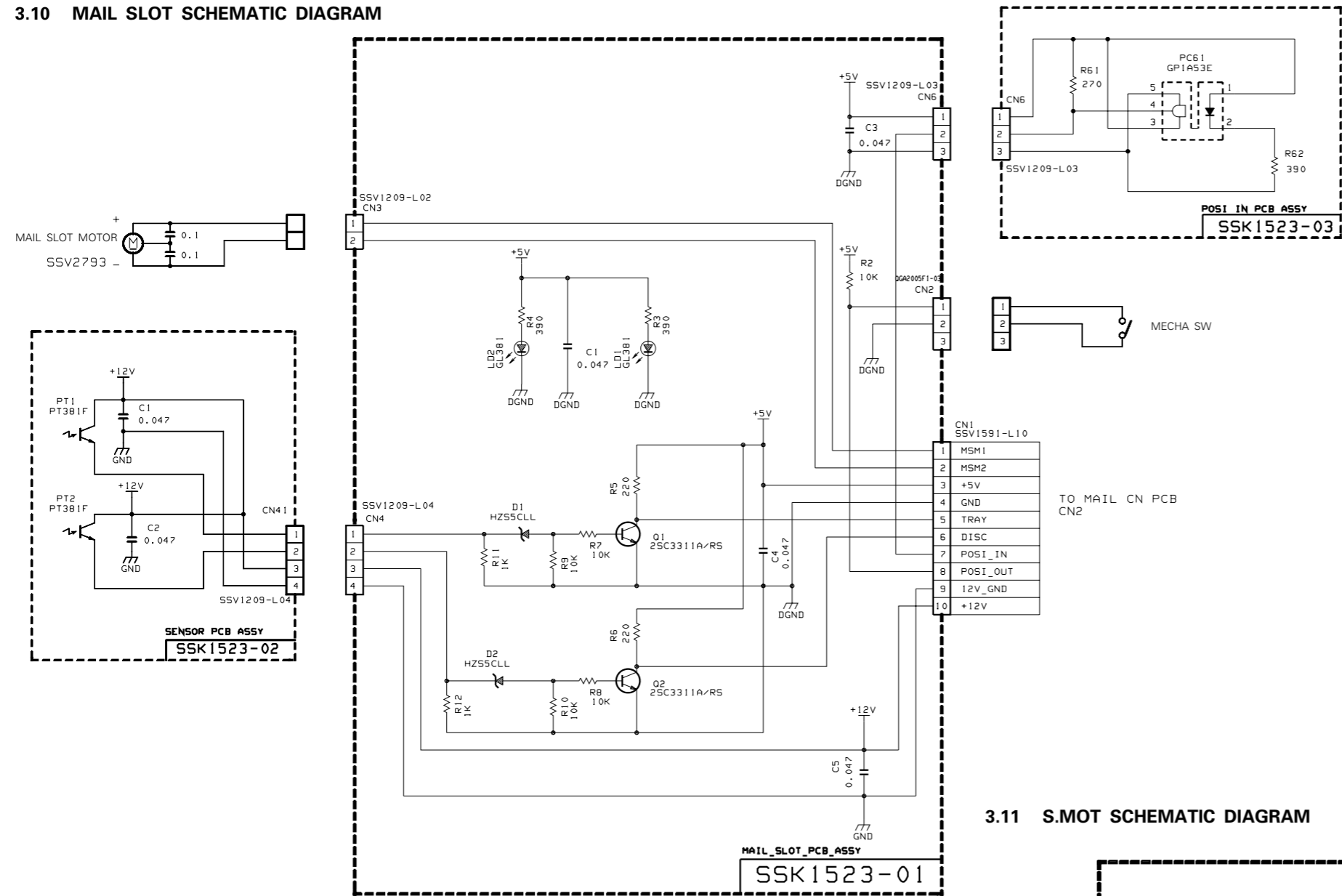

3.11 S.MOT SCHEMATIC DIAGRAM

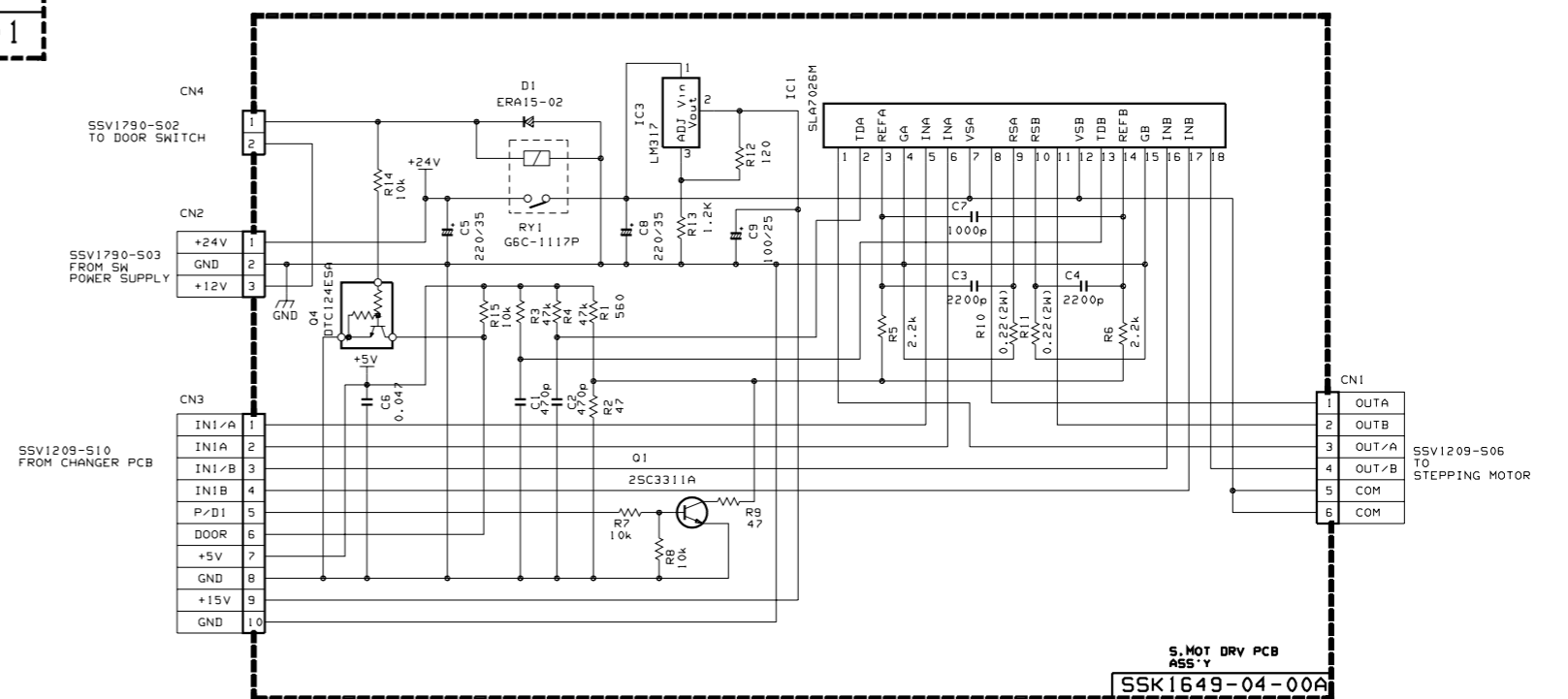

3.12 MAIL SLOT CIRCUIT BOARD

MAIL SLOT

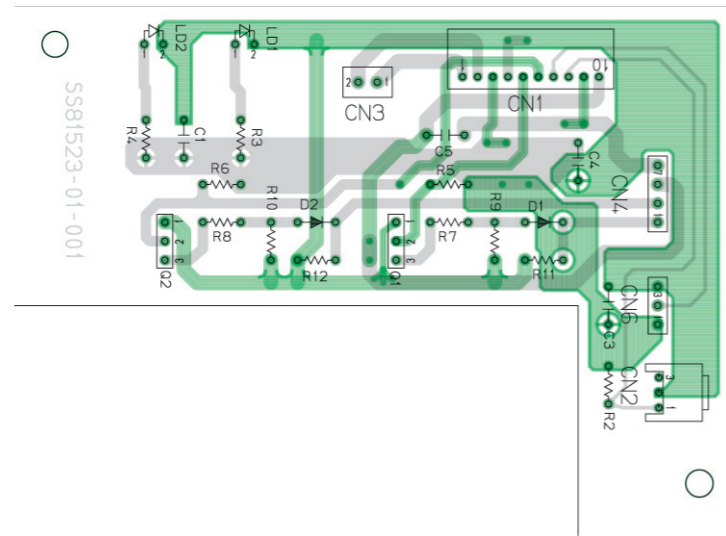

POSI IN

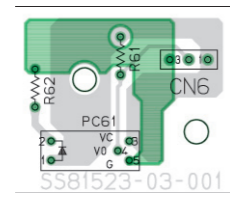

SENSOR

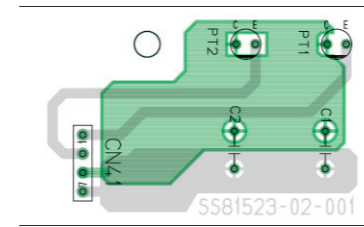

3.13 S.MOT CIRCUIT BOARD

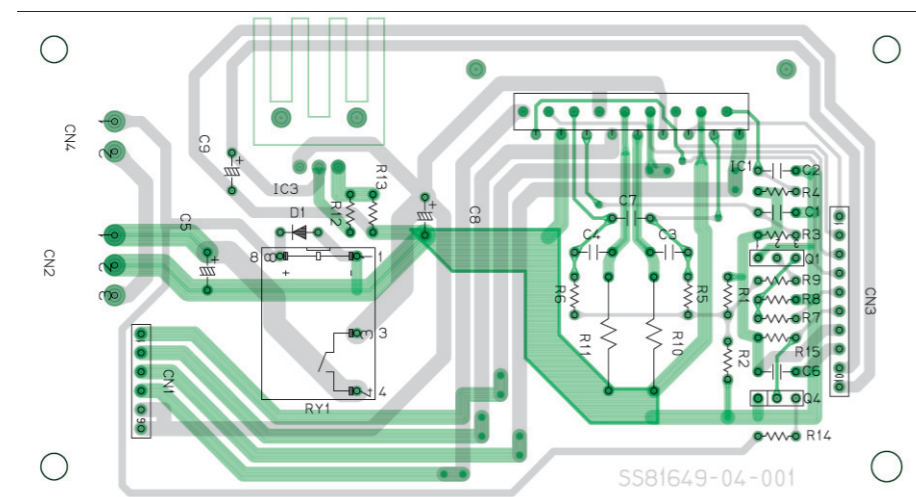

3.14 LVD SCHEMATIC DIAGRAM

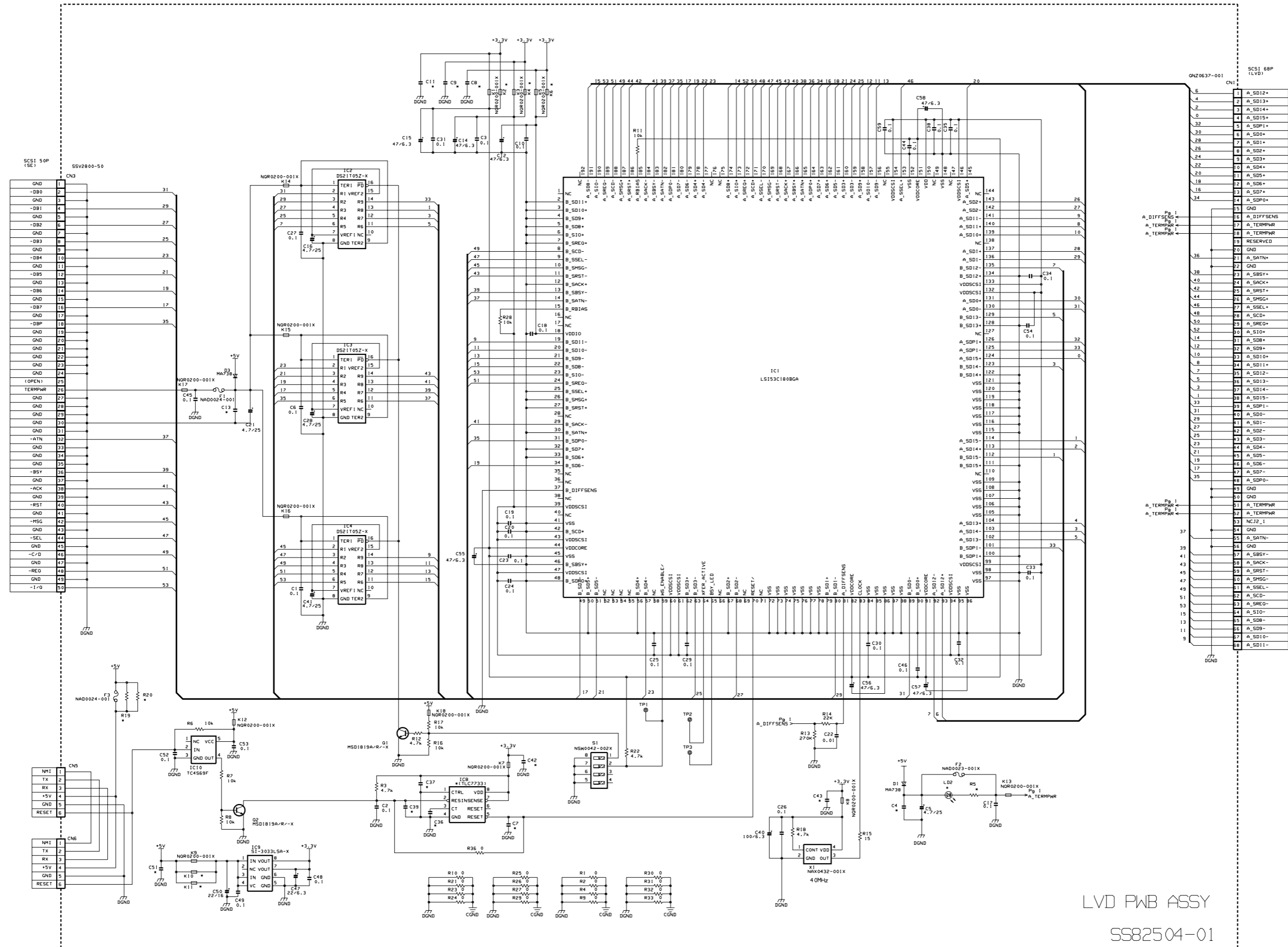

3.15 LVD CIRCUIT BOARD

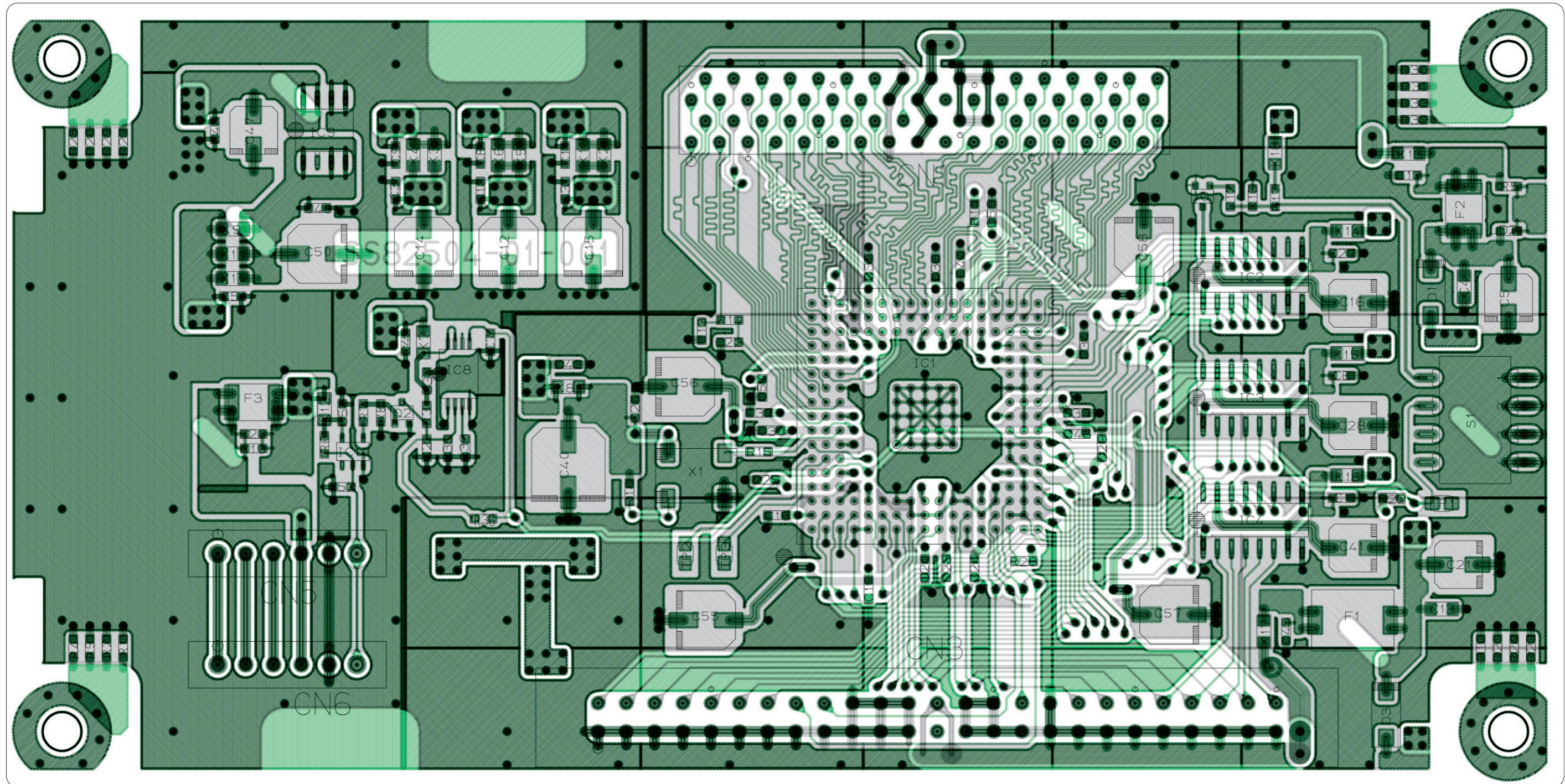

3.16 DISPLAY SCHEMATIC DIAGRAM

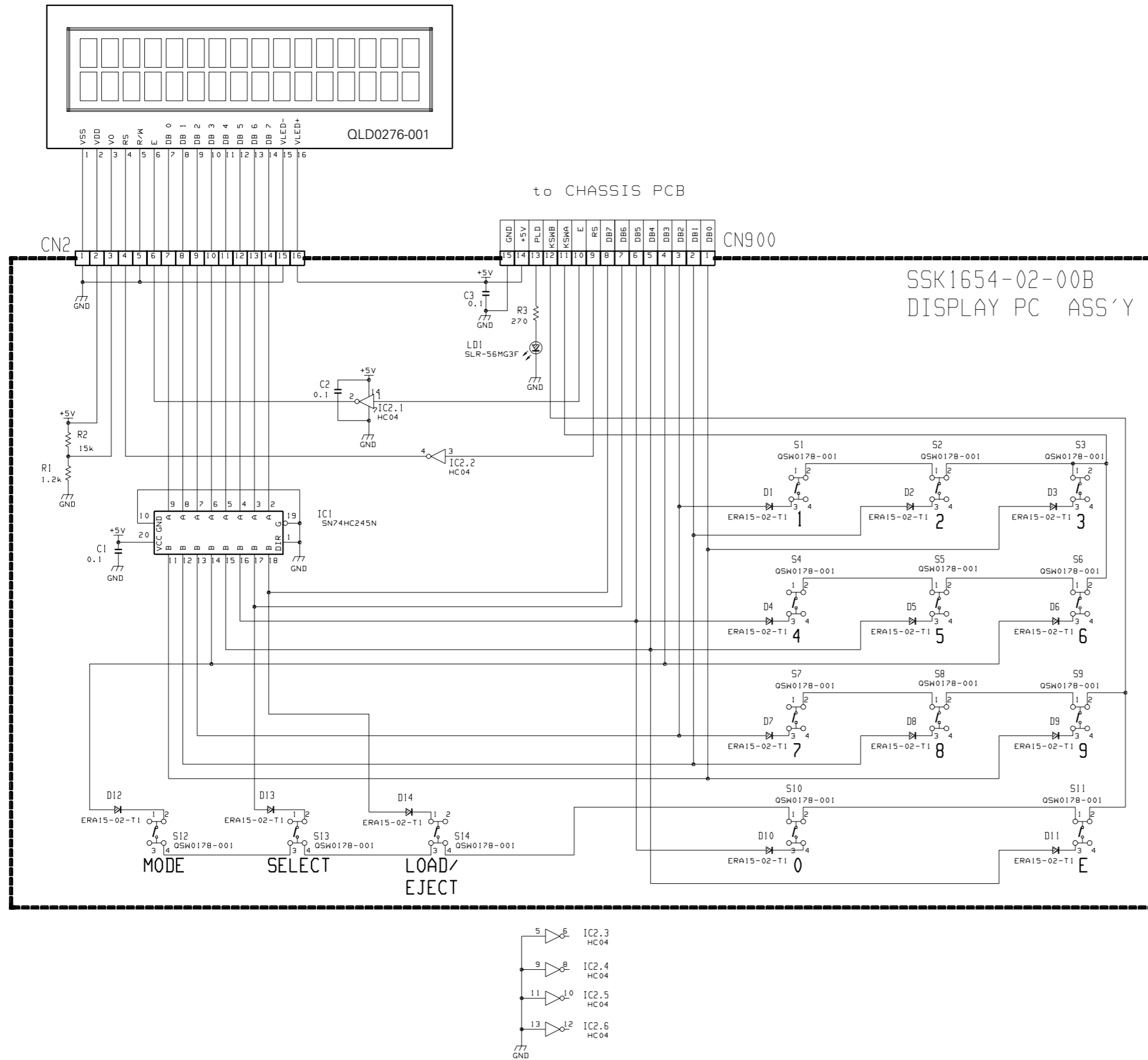

3.17 DISPLAY CIRCUIT BOARD AND OTHER BOARD

■DISPLAY

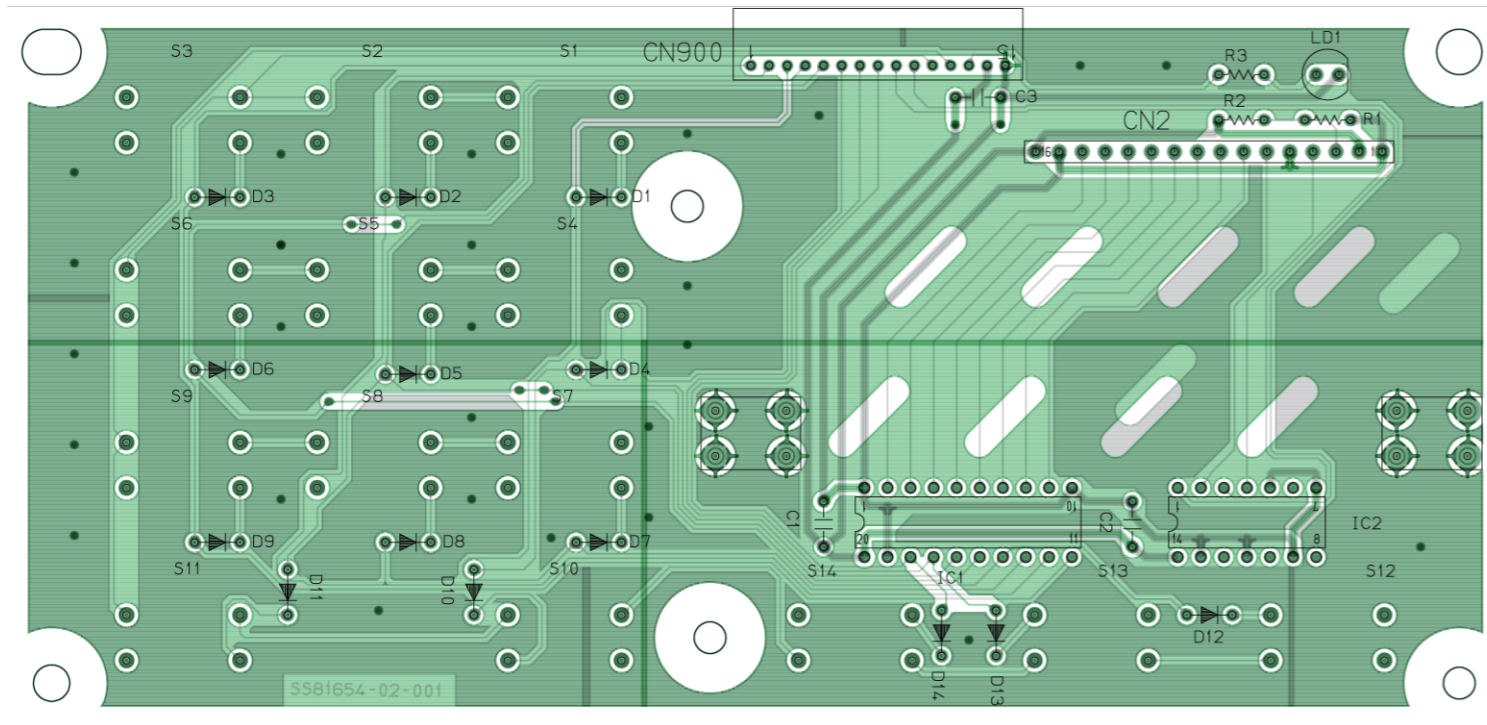

■MAIL CN

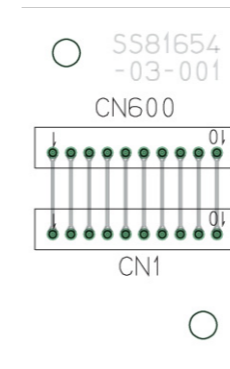

■RS232C

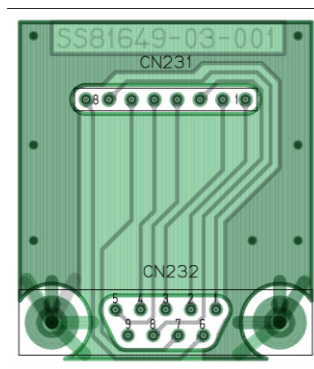

■ROT SENSOR

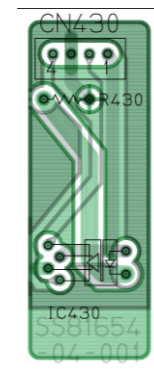

■MAGAZINE SENSOR

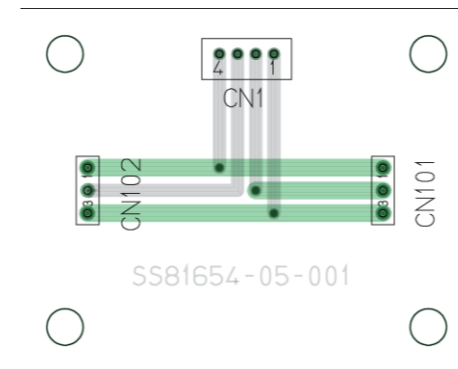

■CONNECTOR

